

INSTALLATION MANUAL

FLATWORK IRONERS IC43316 - IC43320

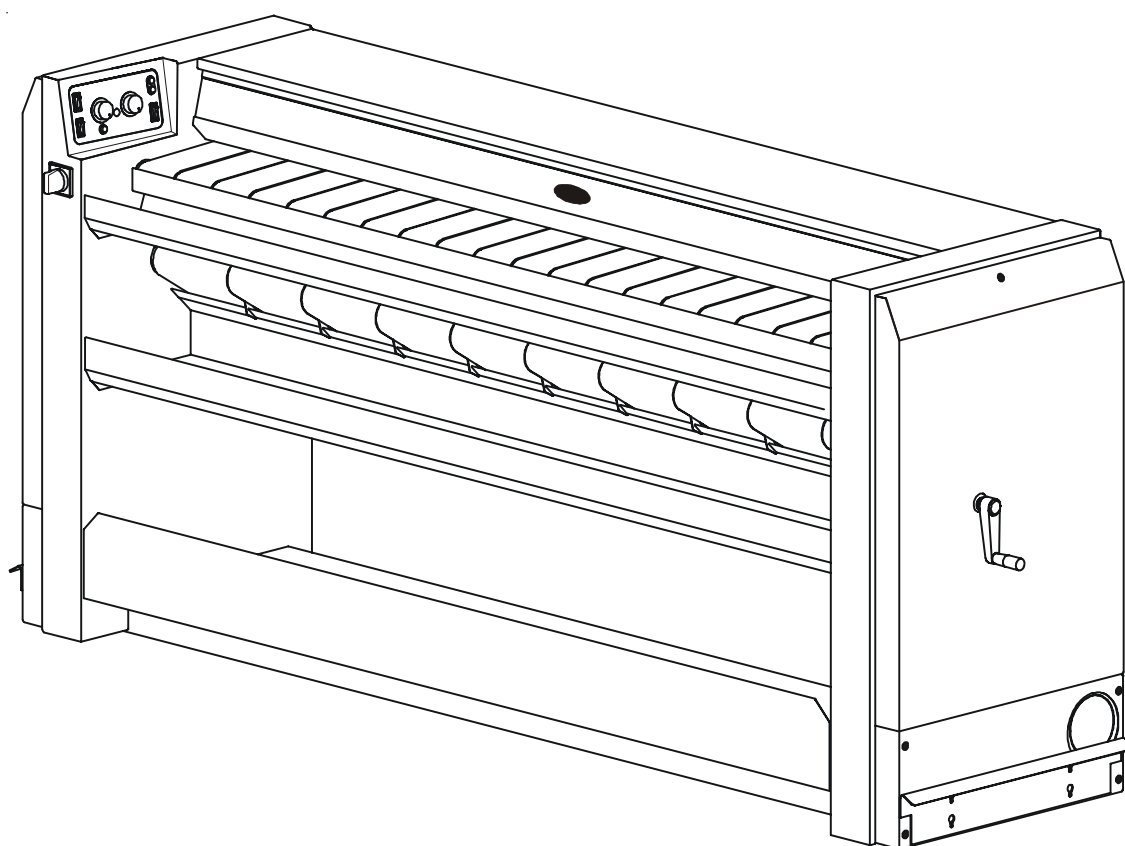

| | | | |
|----------|------|------|----------|
| 01103020 | 0904 | 0 | 0 |
| Notice | Date | Page | |

Pages/Chapters

| | |
|--|------|
| General instructions | |
| Environmental information | 1/1 |
| Preliminary instructions | 2/1 |
| Note about the A.C. power | 3/1 |
| Handling/Weight | |
| Handling | 1/2 |
| Packing- Weight..... | 1/3 |
| Technical characteristics | |
| Ironer | 1/4 |
| Sound level | 3/4 |
| Installation/Putting into service | |
| Installation | 1/5 |
| Levelling the machine | 2/5 |
| Mechanical installation | 3/5 |
| Working place lighting | 4/5 |
| Electricity power supply | 5/5 |
| Gas connection | 10/5 |
| Connection of the ironer evacuation system | 16/5 |
| Operating inspection | 1/6 |
| Appendices | |
| Conversion of measurement units | 1/7 |

| | | | |
|----------|------|------|---|
| 01103020 | 0705 | 1 | 1 |
| Notice | Date | Page | |

Environmental information

Concerned by providing the end user with useful and necessary environmental information, we wish to precise :

- Data about energetic consumptions, wastes (atmospheric and liquid) and sound level are indicated in the paragraph "**Technical characteristics**".
- Forseeing its recycling, this machine is fully dismantable.
- This machine is free from any asbestos.
- In conformity with French regulations:
 - Law No. 76-663 of July 19th 1976
 - Decree No. 77-1133 of September 21st 1977
 - The decree of 7th July 1992
 - The decree of 29th December 1993
 - The decree of 28th December 1999
 - No. 2311 of the nomenclature for classified installations

Commerical linen cleaning laundries and launderettes are subject to:

- prefectural authorisation if the washing capacity exceeds five tonnes per day.
- a declaration to the prefecture if the washing capacity exceeds 500 kilos per day but is below or equal to five tonnes per day.
- In application of the Law of 15 July 1975 and the decrees of 01 April and 13 July 1994 on the disposal of industrial and commercial packing waste «All owners of packing waste producing a weekly volume below 1100 litres can forward these to the local collection and treatment department. If exceeding this volume, the owners of packing waste will ensure their valuation by reuse, recycling or, any other action aiming at producing reusable materials or energy... or provide them contractually to a certified intermediate authorised to transport, trade or broke waste».

Therefore, these texts forbid:

- land filling raw waste
- open air burning or incineration without energy collection.
- Packaging of our machines are according with the provisions of decree 98-638 from July 20 1998 related to environment requirements.

For additional information, do not hesitate to consult with our environmental department.

| | | | |
|----------|------|------|---|
| 01103020 | 0904 | 2 | 1 |
| Notice | Date | Page | |

This machine should be installed in conformance to the health and safety regulations, and only used in a sufficiently aerated area.
Check the instructions before installing or using the machine.



SAFETY

The mechanical and electrical installation of the machine should only be done by qualified personnel.

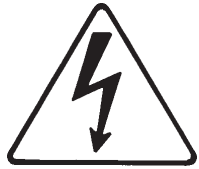

CAUTION

Do not use the machine unless it is plugged into a correctly earthed power socket complying with standards in force.



CAUTION

Under no circumstances should a gas-heating machine be installed in a building which includes a dry-cleaning machine.



CAUTION

Any repairing or maintenance operation should be carried out by a specialist.



CAUTION

It is specially advised not to install the machine on a synthetic floor covering. The frictional electricity may hinder the good working of the machine.

Earthing is compulsory.

The warranty might be cancelled if these instructions are not complied with.

| | | | |
|----------|------|------|---|
| 01103020 | 0305 | 3 | 1 |
| Notice | Date | Page | |

Note about the A.C. power

- According to the EN 60204-1:1997 standard, the machine is provided for AC supplies corresponding to the extracted characteristics below :

4.3.2 AC supplies

Voltage :

Steady state voltage : 0,9...1,1 of nominal voltage.

Frequency :

0,99...1,01 of nominal frequency continuously.

0,98...1,02 short time.

Harmonics :

Harmonic distortion not to exceed 10% of the total r.m.s. voltage between live conductors for the sum of the second through to the fifth harmonic. An additional 2% of the total r.m.s. voltage between live conductors for the sum of the sixth through to the 30th harmonic is permissible.

Voltage unbalance :

Neither the voltage of the negative sequence component nor the voltage of the zero sequence component in three-phase supplies shall exceed 2% of the positive sequence component.

Voltage interruption :

Supply interrupted or at zero voltage for not more than 3ms at any random time in the supply cycle. There shall be more than 1s between successive interruptions.

Voltage dips :

Voltage dips shall not exceed 20% of the peak voltage of the supply for more than one cycle. There shall be more than 1s between successive dips.

| | | | |
|-----------------|-------------|-------------|----------|
| 01103020 | 0705 | 4 | 1 |
| Notice | Date | Page | |

This page is left blank on purpose.



WARNING

It is compulsory that all these operations are undertaken by handling specialists.

1/ Lifting with handling straps

For safety reasons the lifting with handling straps (A) is recommended rather than any other lifting way. Use two handling angles (B) to lift the machine.

2/ Lifting with a fork-lift truck

Always lift at the centre of the machine at (C). In this case please take all most precaution in order to avoid the swing or the fall of the machine during the movement.

3/ Moving along the ground

The machine frame includes a girder, so that the machine can be moved along the ground using rollers, grinding tracks or a trolley.

The two handling angles (B) can be used to lift the machine using hydraulic jacks or poles, so that rollers can be slipped under the girder.

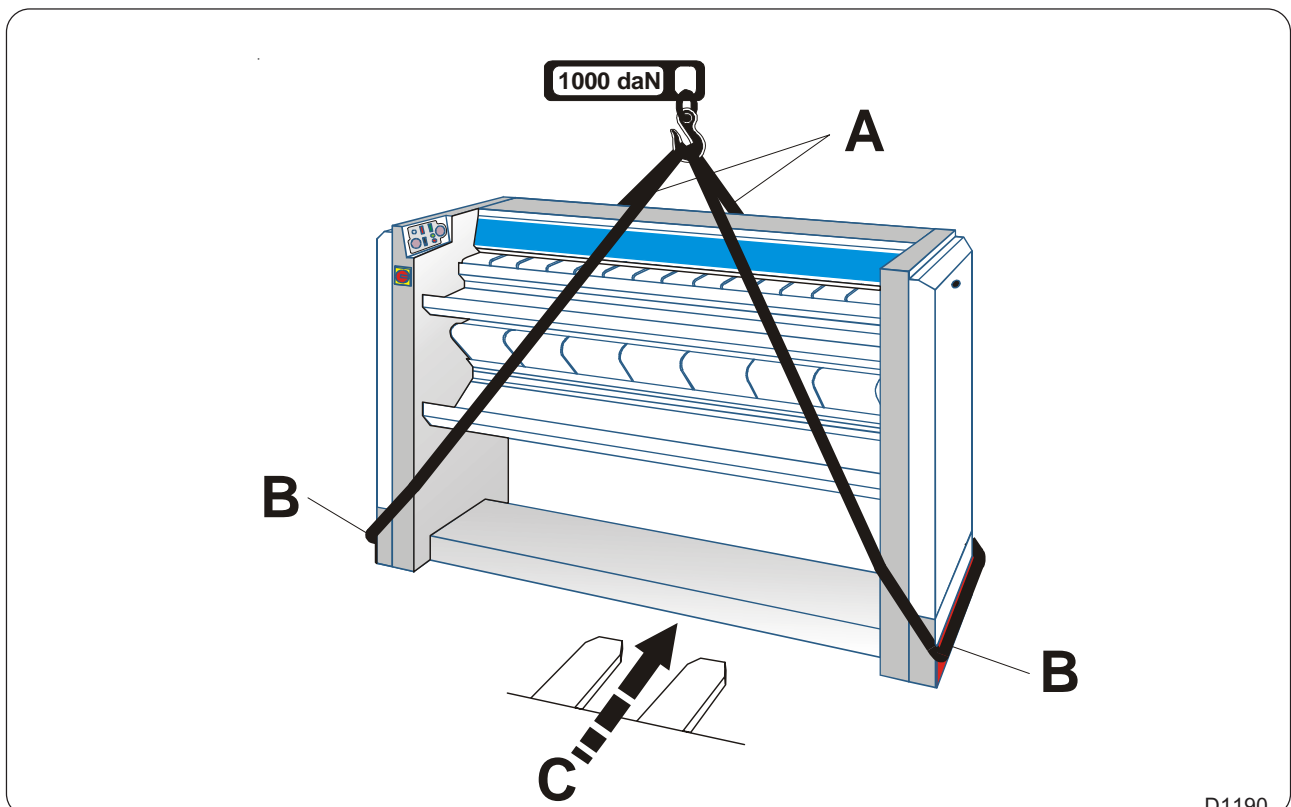

Dryer-ironer

Packing

| Packing dimensions | IC43316 | IC43320 |
|--------------------|------------------|-------------------|
| Box full | | |
| A | 2280 mm / 89.76" | 2695 mm / 106.10" |
| B | 830 mm / 32.68" | 830 mm / 32.68" |
| C | 1430 mm / 56.30" | 1430 mm / 56.30" |
| Machine + crate | | |
| A | 2230 mm / 87.80" | 2630 mm / 103.54" |
| B | 770 mm / 30.31" | 770 mm / 30.31" |
| C | 1430 mm / 56.30" | 1430 mm / 56.30" |
| Machine + pallet | | |
| A | 2170 mm / 85.43" | 2585 mm / 101.77" |
| B | 720 mm / 28.34" | 720 mm / 28.34" |
| C | 1310 mm / 51.57" | 1310 mm / 51.57" |

Weight in daN

| | IC43316 | IC43320 |
|-------------------------|-------------------|-------------------|
| Weight, box full | | |
| Gas | 480 daN / 1059 lb | 525 daN / 1158 lb |
| Electric | 470 daN / 1037 lb | 510 daN / 1125 lb |
| Machine + crate | | |
| Gas | 450 daN / 993 lb | 485 daN / 1070 lb |
| Electric | 440 daN / 971 lb | 470 daN / 1037 lb |
| Machine + pallet | | |
| Gas | 350 daN / 772 lb | 380 daN / 839 lb |
| Electric | 340 daN / 750 lb | 365 daN / 805 lb |

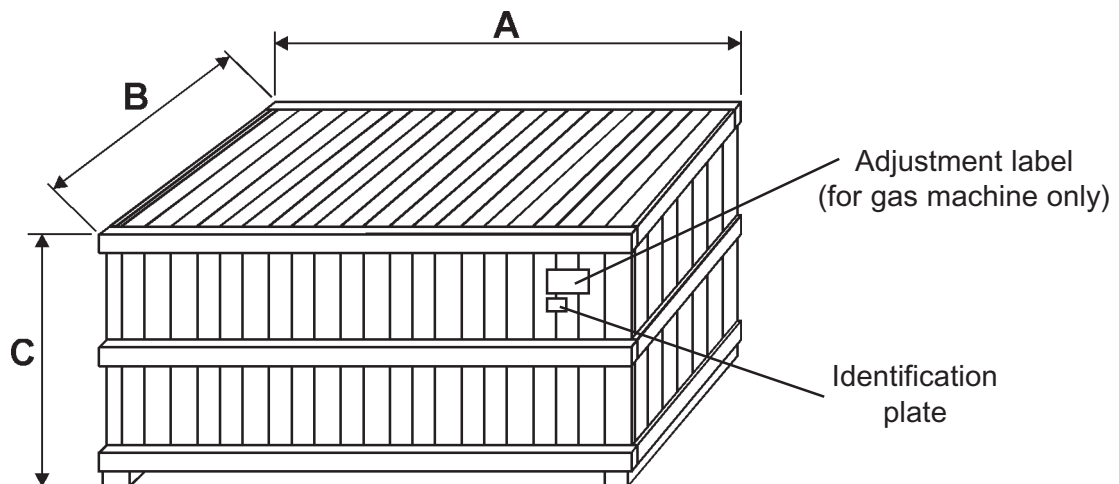

| | | | |
|----------|------|------|---|
| 01103020 | 0904 | 1 | 4 |
| Notice | Date | Page | |

4. Technical characteristics

INSTALLATION MANUAL

Right view

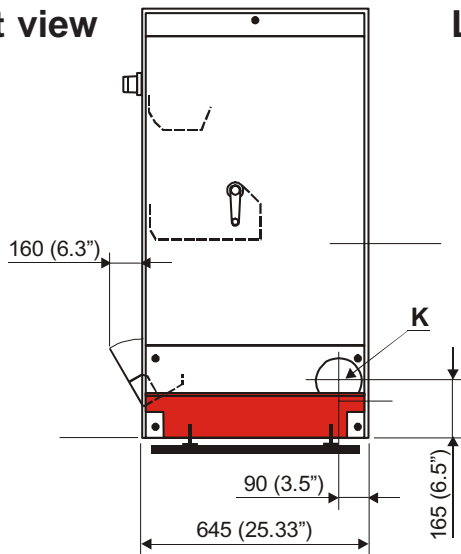

Left view

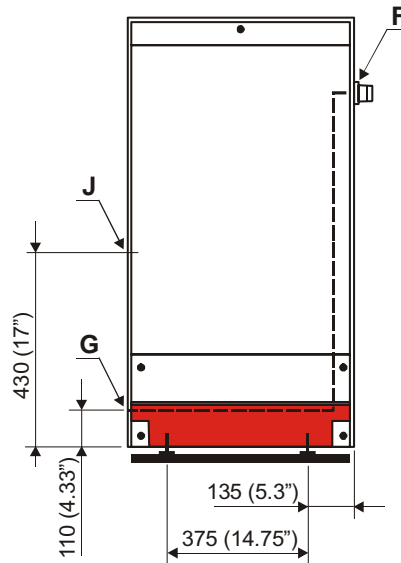

> 1 m (40") A > 1 m (40")

Front view

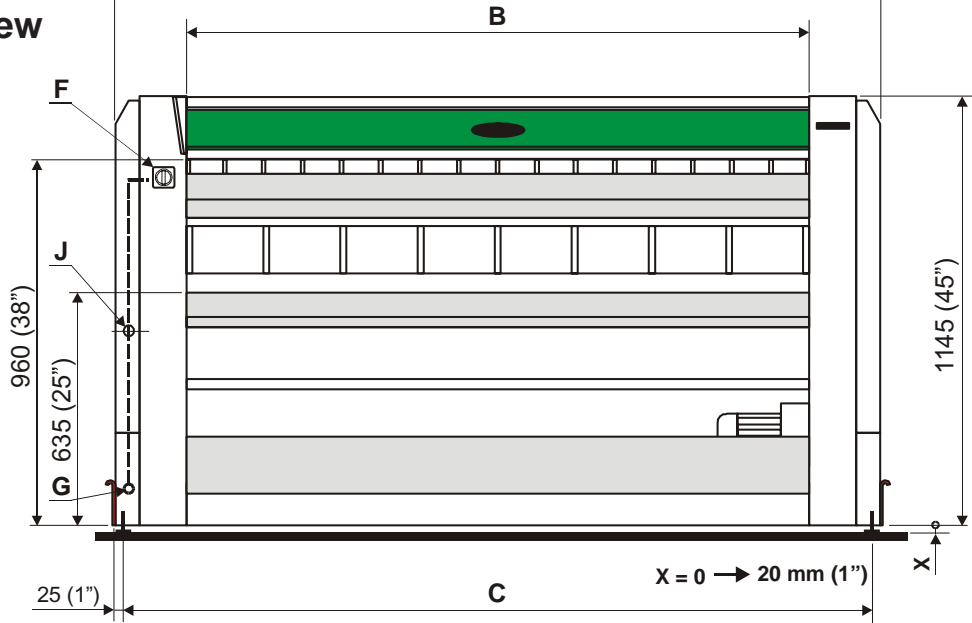

Top view

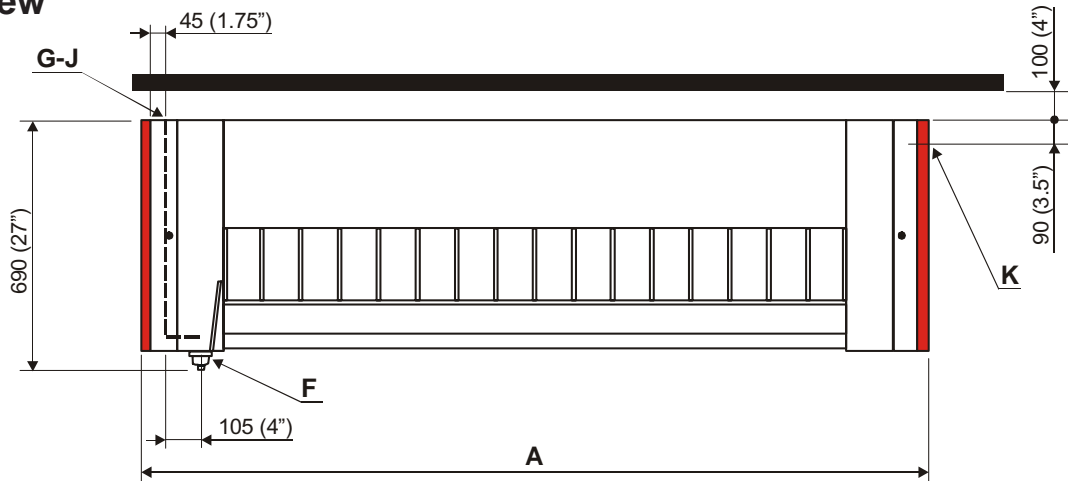

Diagram no. 07100131

Ironer

Characteristics

| | | IC43316 | IC43320 |
|---|----------------|-----------------------------|-----------------------------|
| Ø cylinder | mm | 325 (12.80") | 325 (12.80") |
| Effective working width | mm | 1650 (64.96") | 2065 (81.30") |
| Ironing speed | | | |
| Mini | m/min | 0,5 (1.64 f/min) | 0,5 (1.64 f/min) |
| Maxi | m/min | 5,5 (18.04 f/min) | 5,5 (18.04 f/min) |
| Heating surface | m ² | 1,1 (11.84 f ²) | 1,4 (15.07 f ²) |
| Capacity max. water evaporation, with 50 % residual moisture and 100 % cylinder utilization (according to ISO 9398-1) | kg/h | 19,5 | 24,5 |
| Net weight | | | |
| Gas heating | kg | 295 (651 lb) | 325 (717 lb) |
| Electric heating | kg | 290 (640 lb) | 315 (695 lb) |
| Floor area | m ² | 1,4 (15.07 f ²) | 1,7 (18.30 f ²) |

Dimensions

| | | | |
|-------------------------------|----|---------------|---------------|
| (A) Overall width | mm | 2090 (82.28") | 2505 (98.62") |
| (B) Feeder width | mm | 1650 (64.96") | 2065 (81.30") |
| (C) Width between feet | mm | 1975 (77.75") | 2390 (94.09") |

Connections

- (F)** Main switch to connect electric main cable
- (G)** Inlet for electric main cable
- (J)** Gas inlet DN 20 (3/4" BSP)
- (K)** Drain of vapour or burnt gas Ø 125 mm (5")

Consumptions

Gas heating

| | | | |
|--------------------------------|-----|-----|-----|
| Installed electric power | kW | 0,5 | 0,5 |
| Maximum electrical consumption | kWh | 1,2 | 1,2 |
| Installed heating power | kW | 20 | 25 |

Electric heating

| | | | |
|--------------------------------|-----|------|------|
| Installed electric power | kW | 18,5 | 23 |
| Maximum electrical consumption | kWh | 18,5 | 22,5 |

Heat loss : 3 % of installed heating power

| | | |
|--|-------------------|--|
| Exhaust air max. with no pressure at 15 °C (59 °F) | | |
| | m ³ /h | 426(251 f ³ /min) 515(251 f ³ /min) |

Total pressure with no flow : 540 Pa (0.07832 PSI)

Admissible head loss on evacuation : 200 Pa (0.029 PSI)

Sound level

Airborne noise emitted by the machine (values established from measurements made on the machine at points A, B, C, D).

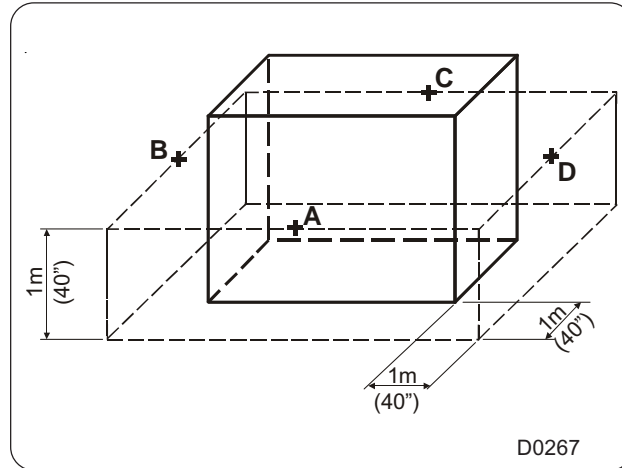

Weighted sound pressure level (A) in dB (A) for an IC433.

| | A | B | C | D |
|---------|----|----|----|----|
| IC43316 | 63 | 62 | 63 | 65 |
| IC43320 | 63 | 62 | 63 | 65 |

Unpacking

Release the machine from its pallet by cutting the plastic film and remove the pallet, removing the red transport clamps with an appropriate spanner.

Check that no damage has been caused during transport.

Installation

The installation must be done by competent technicians in accordance with local codes and regulations. When there are not local codes and regulations, the installation **must be comply** with european standards applicable.

The machine must be installed on a horizontal and firm floor, capable of supporting its weight.

Ironers are provided with four leveling screws to facilitate leveling (one on each corner of the sole plate).

Place the dryer so that it is easy for the user and the service technician to do their work.

- Leave at least 0.1 m (4") between the machine and the wall against which it is placed.
- Leave at least 1 m (40") between the machine and a wall or another machine on the left side in order to be able to carry out an intervention on the caisson.

However, note that if you can, it is recommended that you should leave sufficient space for maintenance of the heating box to avoid having to move the dryer (minimum length A on the left side).

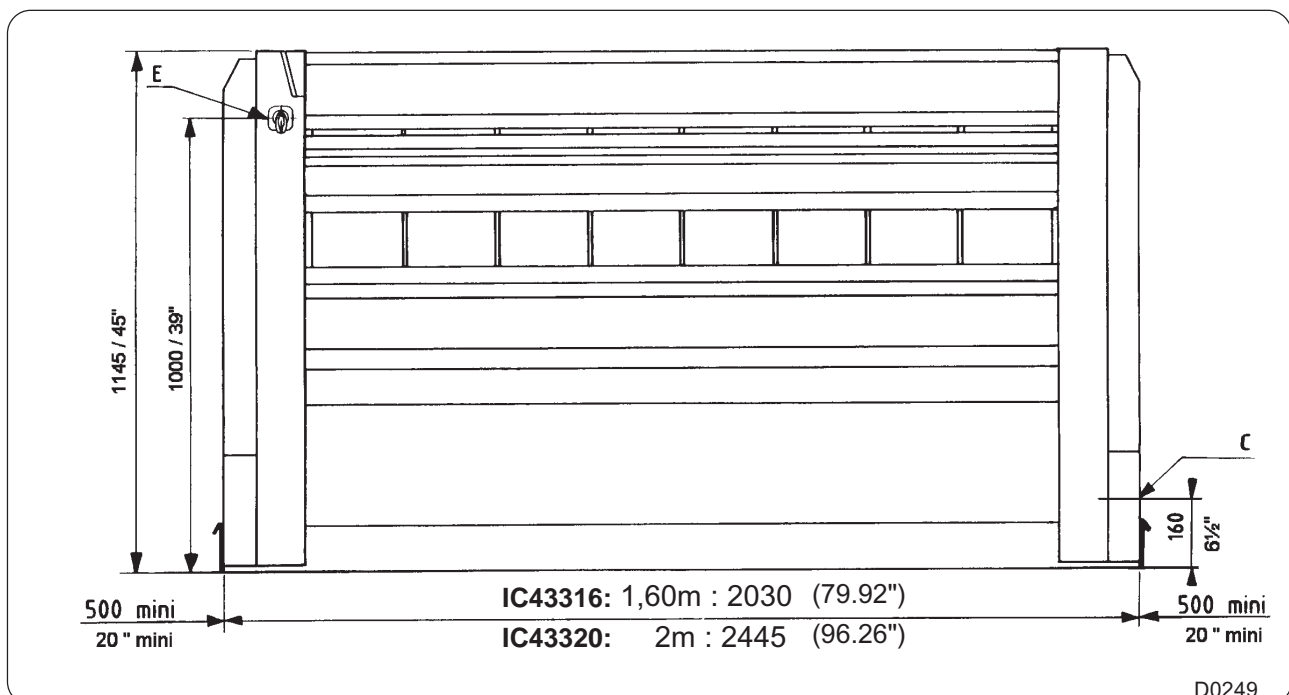

Screw off the screws to remove the red transport angles (benchmark E) with a key.

CAUTION :

Do not remove these screws.

Keep these angles to eventually lift the machine.

Block the screws which maintained these angles.

Dismantling of the casing :

Remove the black shutter and then the screw (A).

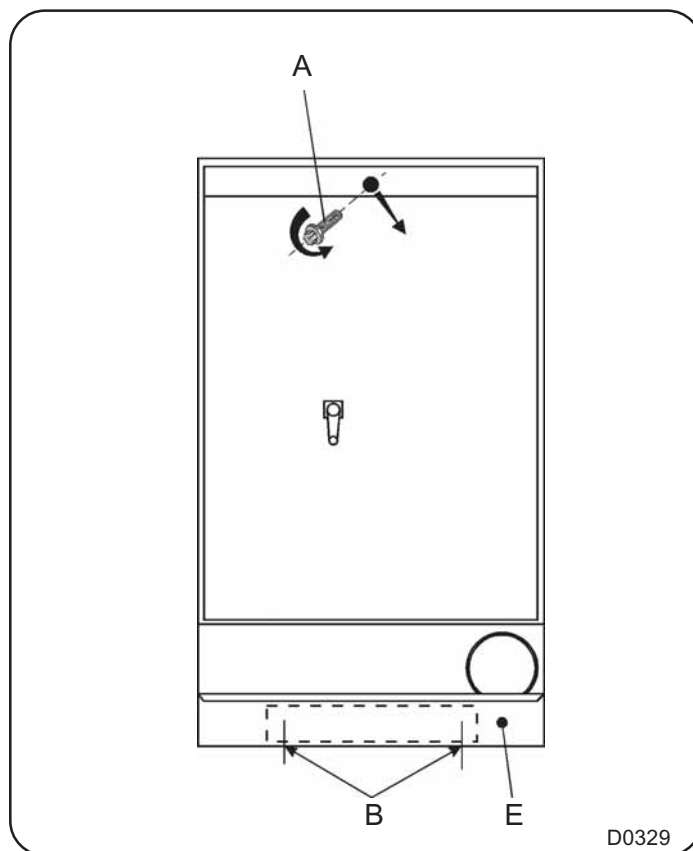

Levelling the machine

Assemble the four adjustment feet (B) to make the levelling possible.

They are to be fitted on each side of the machine and can be reached from outside underneath.

Act on the adjusting feet (B), and level the machine and then fix by the locknut (D).

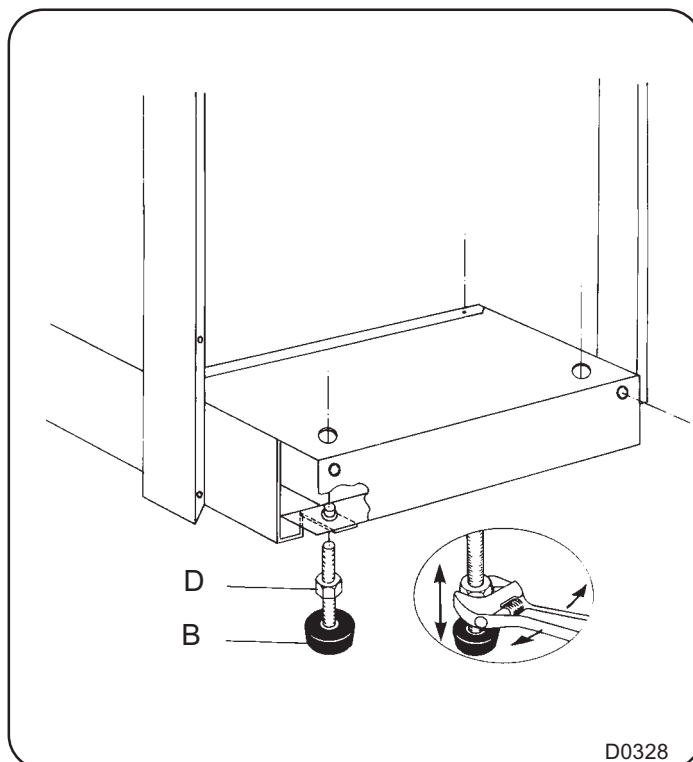

Mechanical installation

Check with a spirit level placed on the sole plate for the longitudinal direction and the machine top cover for the transverse direction (see sketch).

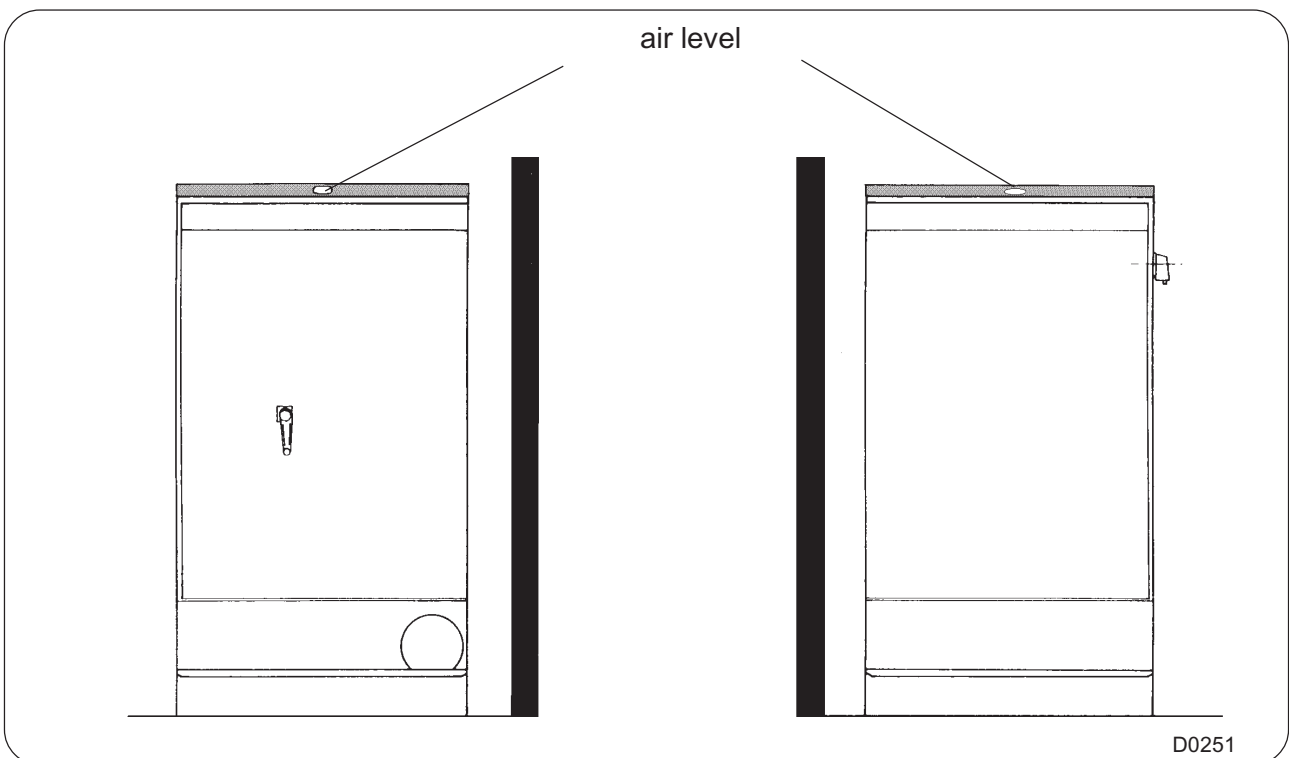
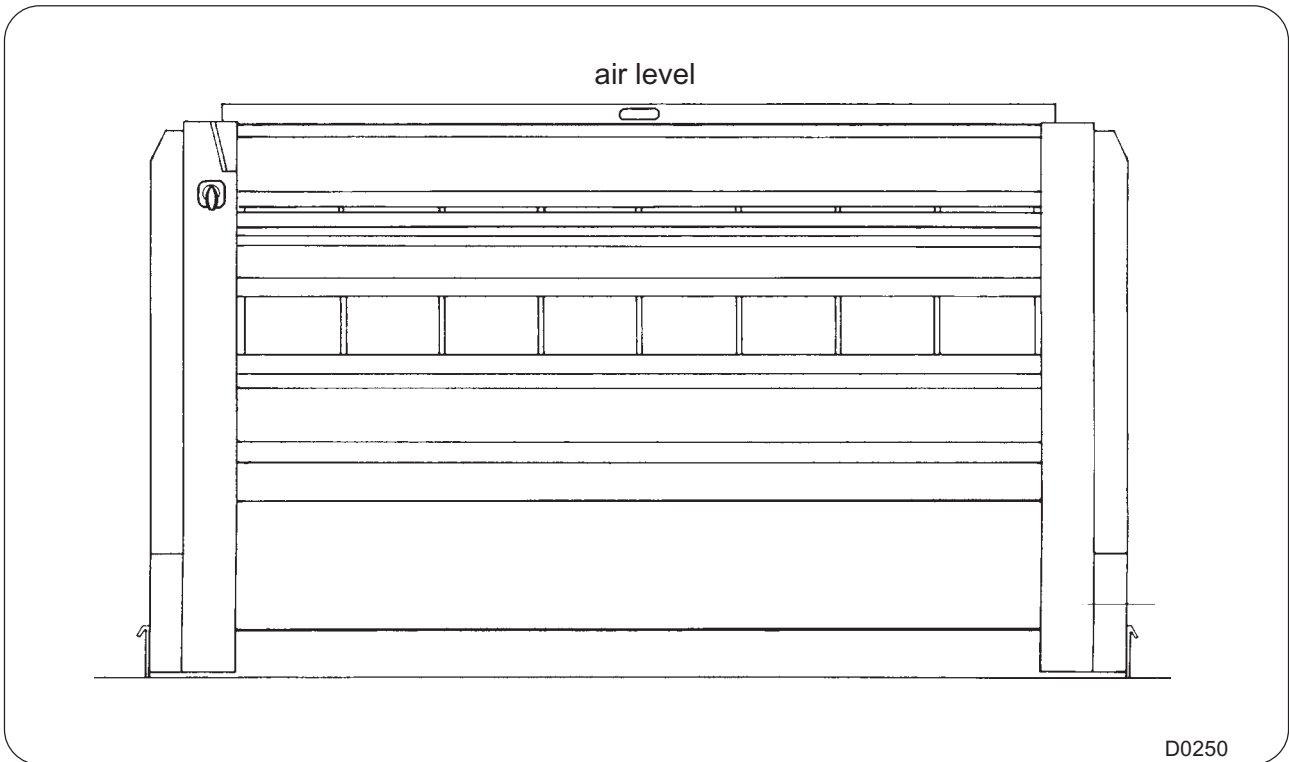

| | | | |
|----------|------|------|---|
| 01103020 | 0904 | 4 | 5 |
| Notice | Date | Page | |

Machine with steel cylinder option

Before the very first starting operation, it is necessary to take off the protective paper rolled round the heating cylinder (for steel cylinder only).

To do so, you have to install the crank (V) that you have found in the caisson together with this instruction handbook (see photo).

Turn the crank to make the cylinder rotate and remove the protective paper.

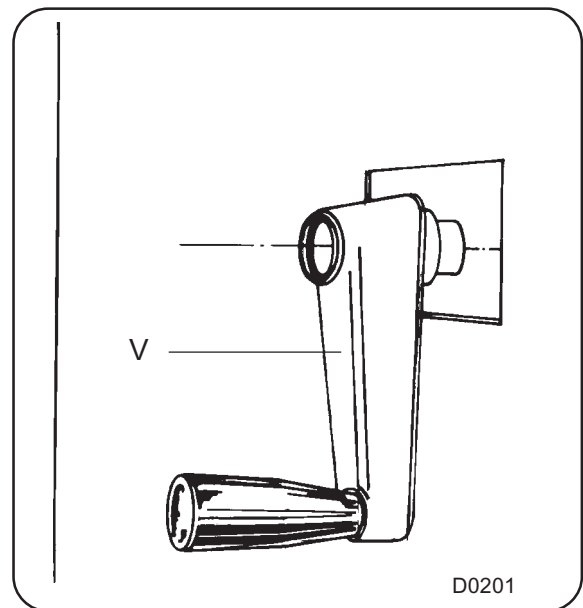

Working place lighting

The lighting should be designed so as to avoid eye strain for the operator; it should be uniform without any glare, and should be sufficient to detect any hazards.

The average lighting value on the feeding table recommended by the clothing industry for inspecting linen is **300** lux.

Whenever possible, the working place should be illuminated by daylight.

Electricity power supply

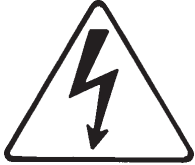

CAUTION

Prior to use, the ironer should be plugged into a correctly earthed power socket complying with the standards in force.



SAFETY

The electrical installation of the machine must be undertaken by qualified personnel.



CAUTION

Ensure that the electrical voltage is correct and that the power of your supply is sufficient, before connecting the machine.

For each machine, install a fixed multipole circuit breaker (or fuses protector) in the laundry main cabinet.

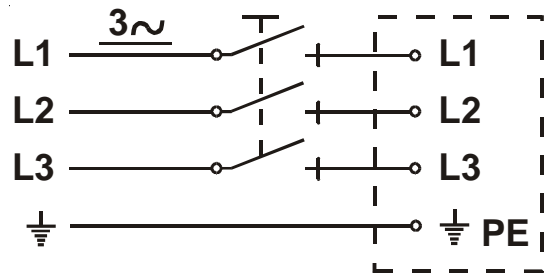

D0466

Pass the machine power supply cable through the orifice (see sketch).

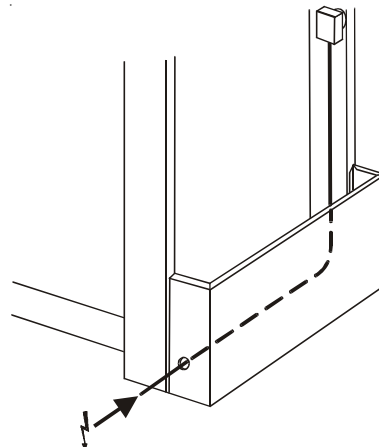

D1039

Electricity power supply

IMPORTANT : Check that the mains voltage is correct and that your installation is powerful enough before connecting the machine (see chapter 5 page 9 for the cross sectional areas of cables).

Insert the feeding cable in the designed port (letter B on the foundation plan on the rear left side of the caisson).

Dismantle (following the pattern) the general switch (E) by activating the red lever (M) downward **or** push the red button (K) to separate the body from the head of the switch, and then pull it backward following arrow (F).

Connect this cable on the general switch (E) diagram D0180 observing the location of the threads.

- L1 Phase no 1
- L2 Phase no 2
- L3 Phase no 3
- PE Earth connection

To reassemble the body of the switch, reverse the operation (activate (M) upward to lock).

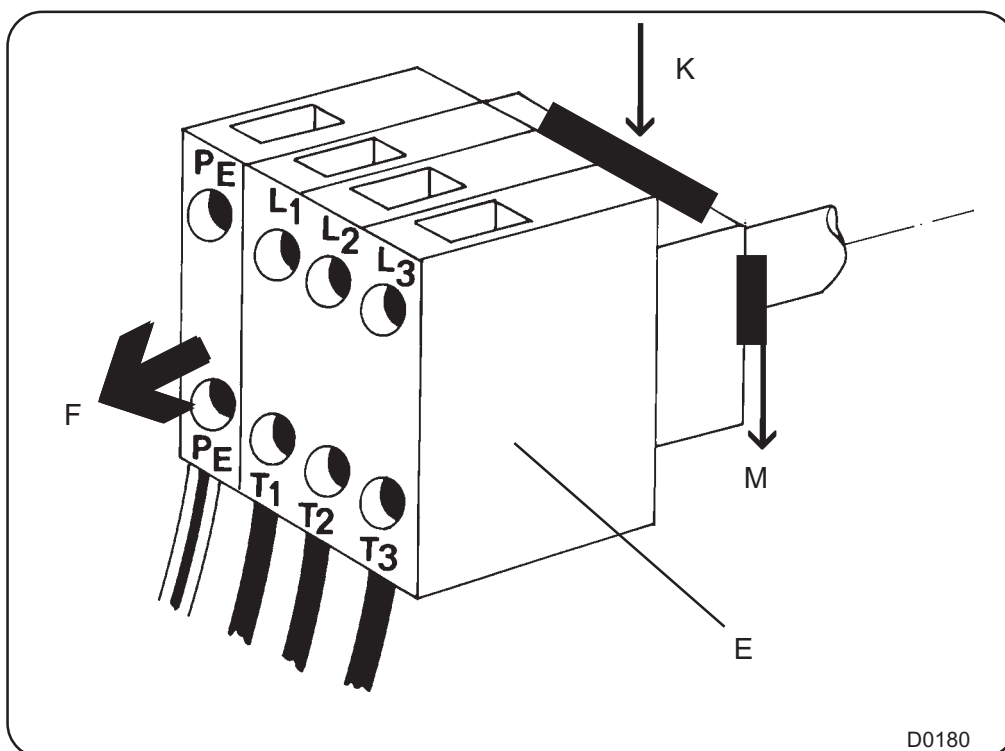

Connect the power supply cable on the machine main switch.

Check the order of phases on the switch terminals (see marks L1, L2, L3 and PE on the switch).

(Check operation, see chapter no.10).

NOTE : you must respect the fan rotation direction.

Connection diagrams for the control circuit power supply transformer (T1) as a function of the various customer power supply voltages.
400 volt power supply.

Measure the power supply voltage at the transformer primary with a voltmeter between the transformer 0 and 400 volt terminals.

- If the voltage is equal to 400 volts, do not touch the transformer connection which must be as shown in the adjacent figure.

- If the voltage is > 400 volts (for example: 420 or 430 volts), connect the wires to the transformer as shown in the adjacent figure.

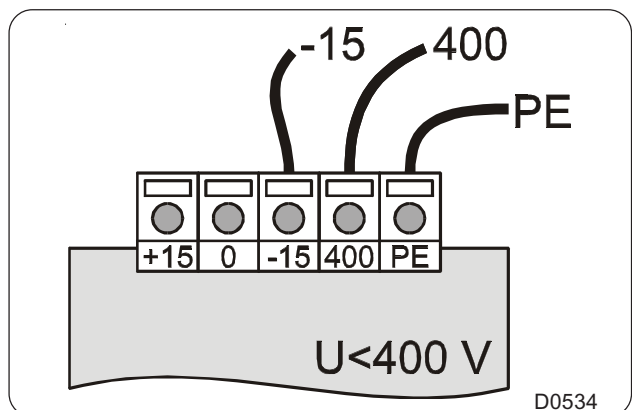
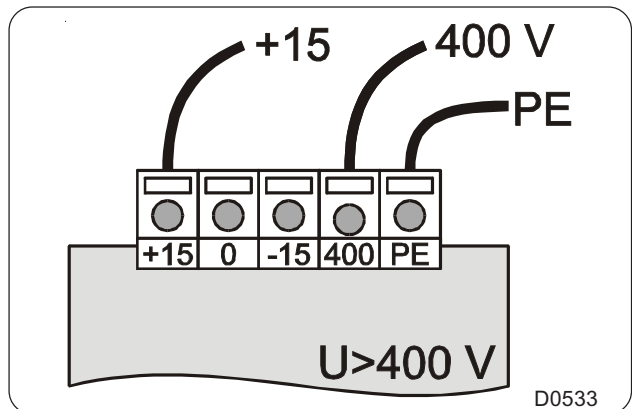
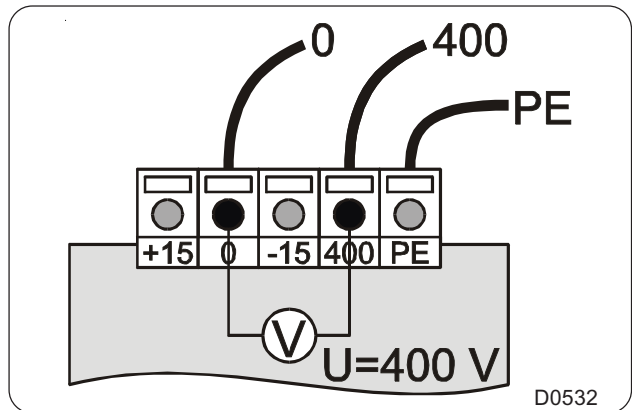
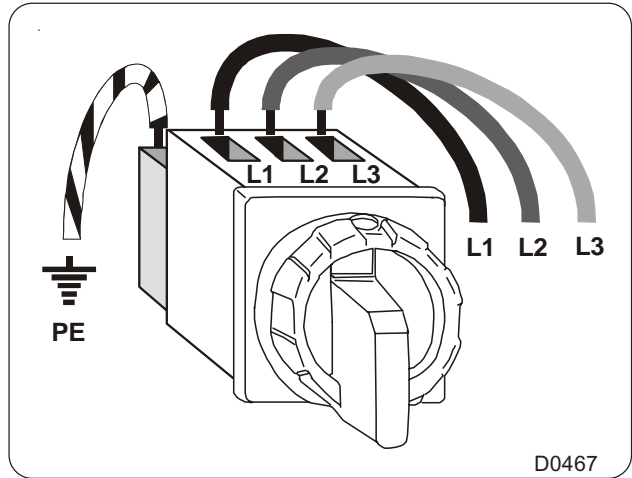

Note : we recommend that you should adopt this solution even if the voltage is normally equal to 400 volts but may be subjected to temporary variations, so that you do not apply an overvoltage to the electrical equipment in your machine.

- If the voltage is significantly < 400 volts (for example: 370 or 380 volts), connect the wires to the transformer as shown in the adjacent figure.

The feeder cable sections mentioned in our literature are given **only as a guide**.

To obtain a value perfectly suited to your own application and which takes account of the different correction factors in respect of your plant, refer to the tables below.

Table 1 (in accordance with EN standard 60204-1-1992)

Values given for :

- Cable with copper conductors
- Cable with PVC insulation (for other insulants see Table 3)
- Ambient temperature 40 °C max. - 104 °F max. (for others see Table 2)
- Three-phase cable under load without including starting currents
- BT / C/ E cable layout.

| Cable Section (mm ²) | Maximum Admissible Current (amperes) | | |
|--------------------------------------|---|----------------|------------|
| | Seated in cable Duct or Cable Trough | Wall fixing | Cable tray |
| | B2 | C | E |
| 3 x 1.5 | 12.2 | 15.2 | 16.1 |
| 3 x 2.5 | 16.5 | 21 | 22 |
| 3 x 4 | 23 | 28 | 30 |
| 3 x 6 | 29 | 36 | 37 |
| 3 x 10 | 40 | 50 | 52 |
| 3 x 16 | 53 | 66 | 70 |
| 3 x 25 | 67 | 84 | 88 |
| 3 x 35 | 83 | 104 | 114 |
| 3 x 50 | - | 123 | 123 |
| 3 x 70 | - | 155 | 155 |

Table 2

(Correction factors for different ambient temperatures)

| Ambient Temperature | Correction Factor |
|----------------------|-------------------|
| 30 °C / 86 °F | 1.15 |
| 35 °C / 95 °F | 1.08 |
| 40 °C / 104 °F | 1.00 |
| 45 °C / 113 °F | 0.91 |
| 50 °C / 122 °F | 0.82 |
| 55 °C / 131 °F | 0.71 |
| 60 °C / 140 °F | 0.58 |

Table 3

(correction factor for different cable insulating materials)

| Insulating Material | Max. Working Temperature range | Correction Factor |
|-----------------------------------|--------------------------------|-------------------|
| PVC | 70 °C / 158 °F | 1.00 |
| Natural or Synthetic Rubber | 60 °C / 140 °F | 0.92 |
| Silicone Rubber | 120 °C / 248 °F | 1.60 |

Table 4
(B2, C and E correction factors for cable grouping)

| Number of Cables | B2 Seated in Cable Duct | C Wall Fixing or Cable Trough | E Cable Tray |
|------------------|-------------------------|-------------------------------|--------------|
| 1 | 1.00 | 1.00 | 1.00 |
| 2 | 0.80 | 0.85 | 0.87 |
| 4 | 0.65 | 0.75 | 0.78 |
| 6 | 0.57 | 0.72 | 0.75 |
| 9 | 0.50 | 0.70 | 0.73 |

The total current included for using Table 1 should be the maximum rated current for the machine divided by the product of the different correction factors. Other correction factors may also be applied ; consult the cable manufacturers.

Calculation : Example

- The machine has a rated current of 60 A.
- The ambient temperature is 45 °C ; Table 2 gives a correction factor of 0.91.
- Rubber cable insulant : Table 3 gives a correction factor of 0.92.
- The cable is fixed directly to the wall (Column C), with 2 cables side by side. Table 4 gives a correction factor of 0.85.

60 A

Total current : $\frac{60}{0.91 \times 0.92 \times 0.85} = 84 \text{ A}$

Taking Column C in Table 1 (wall fixing), we obtain a minimum cable section of : **3 x 25 mm²**.

| Machine type | Supply Voltage | Installed Power | Heating | Rated intensity | Main Switch | Connection Cable Section | Fuse |
|--------------|---------------------------|-----------------|----------|-----------------|-------------|--------------------------|----------|
| 3316 | 380/415V 3+E ~ 50/60 Hz | 0.5 kW | Gas | 1 A | 3 x 12 A | 4 x 2.5 mm ² | 3 x 12 A |
| 3316 | 220/240V 3+E ~ 50/60 Hz | 0.5 kW | Gas | 2.5 A | 3 x 12 A | 4 x 2,5 mm ² | 3 x 12 A |
| 3316 | 200/208V 3+E ~ 50/60 Hz | 0.5 kW | Gas | 2.5 A | 3 x 12 A | 4 x 2,5 mm ² | 3 x 12 A |
| 3316 | 220/240V P+N+E ~ 50/60 Hz | 0.5 kW | Gas | 2.5 A | 2 x 12 A | 3 x 2,5 mm ² | 2 x 12 A |
| 3316 | 380/415V 3+E ~ 50/60 Hz | 18.5 kW | Electric | 26.7 A | 3 x 32 A | 4 x 6 mm ² | 3 x 32 A |
| 3320 | 380/415V 3+E ~ 50/60 Hz | 0.5 kW | Gas | 1 A | 3 x 12 A | 4 x 2.5 mm ² | 3 x 12 A |
| 3320 | 220/240V 3+E ~ 50/60 Hz | 0.5 kW | Gas | 2.5 A | 3 x 12 A | 4 x 2.5 mm ² | 3 x 12 A |
| 3320 | 200/208V 3+E ~ 50/60 Hz | 0.5 kW | Gas | 2.5 A | 3 x 12 A | 4 x 2.5 mm ² | 3 x 12 A |
| 3320 | 220/240V P+N+E ~ 50/60 Hz | 0.5 kW | Gas | 2.5 A | 2 x 12 A | 3 x 2.5 mm ² | 2 x 12 A |
| 3320 | 380/415V 3+E ~ 50/60 Hz | 23 kW | Electric | 32.5 A | 3 x 40 A | 4 x 10 mm ² | 3 x 40 A |

Gas connection



The installation of the gas supply should be carried out by trained staff.

To be provided by the customer a filter, a manual stop valve and a pressure reducing valve BUTANE 29 gr., PROPANE 37 or 50 gr. or NATURAL GAS according to the kind of gas used.

Check that the diameter of injectors (I) is adequate for the kind of gas of your installation (see table t0134). The machine is delivered with extra injectors in a plastic envelope. There is also a sheet metal plate with a cork joint or an adjusting head to feed the machine with another gas.

Connect the installation at the back of the machine (B on the foundation plan) to diameter DN 20 (¾" BSP).

- | | | | |
|---|---------------|---|------------------------|
| A | Gas burner | I | Injectors |
| B | Gas admission | P | Venturis |
| C | Filter | G | Venturis support plate |

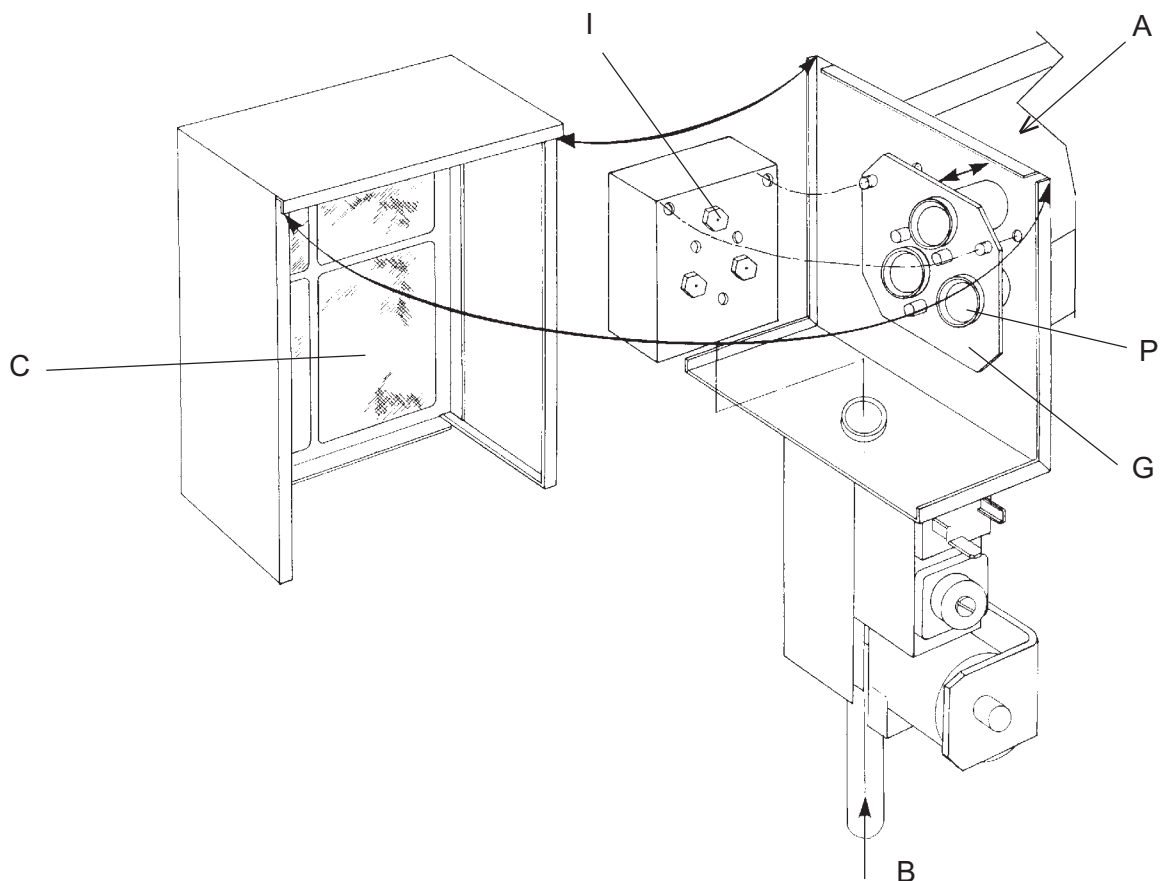

The machine is adjusted at the plant to be suitable for the kind of gas specified on the order. If you have to supply your machine with gas in a family different from the gas for which your machine was adjusted, proceed as follows :

Check that the diameter of the injectors is adequate for the kind of gas of your installation (see table of injectors). The machine is delivered with extra injectors in a plastic envelope.

Testing pressures

According to the EN 437 standard, the values of the testing pressures mentioned in our various documents are values for static pressures taken at the gas inlet connection of the machine; the heating of the machine being on.

Changing to a gas in the same family (type H or L)

- Adjust the gas outlet pressure (see correspondence in the tables).

Changing to a gas in a different family (from type H or L to butane or propane)

- Change the 3 injectors with joints (see correspondence in the tables).
- Unscrew the fixing screws (V) and remove the adjusting head (J) as well as its cork (T), keep these parts in case a change would be necessary.
- Replace it by the cork (L) and the plate (P).
- Screw the two screws and block.

Changing to a gas in a different family (from butane or propane to type H or L)

- Change the 3 injectors with joints (see correspondence on the tables).
- Unscrew the fixing screws (V) and remove the plate (P) as well as the cork (L), keep these parts in case a change would be necessary.
- Set the cork (T) and the adjustment head (J).
- Screw the two screws (V) and block.

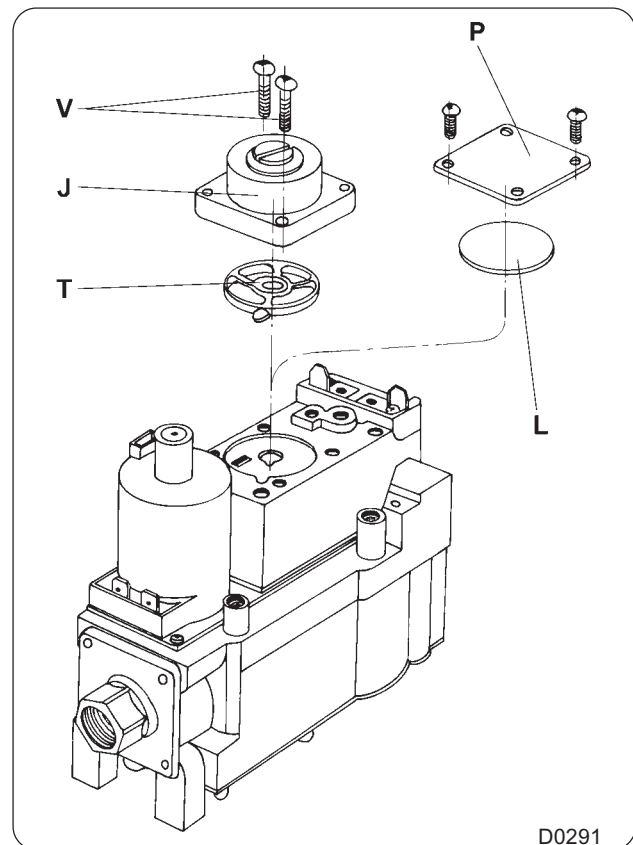



IMPORTANT

Adjustments should be made by qualified personnel only.

Adjustment and checking of the outlet pressure

The gas outlet pressure of the solenoid valve is adjusted at the factory. If you have to make another adjustment, proceed as follows.

- A Inlet
- B Outlet
- D Outlet pressure regulator adjustment screw plug
- E Inlet pressure tapping
- F Outlet pressure tapping
- T Head regulation

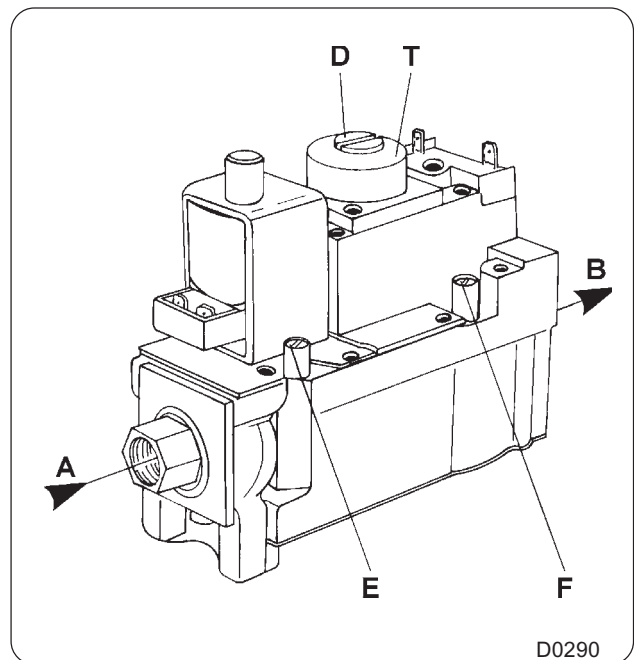

- 1/ Close the gas inlet and remove the binding screw from the pressure tapping (F) and connect the manometer tube.
- 2/ The electricity supply must be energized otherwise gas will not be supplied to the burner.
- 3/ Open and check the gas inlet main burner using the manometer on the pressure tapping (F).
- 4/ Remove pressure regulator cap (D).
- 5/ Using a screwdriver, slowly turn the adjustment screw until the required pressure (P) is indicated on manometer (see tables on the following pages).
Turn the adjustment screw clockwise to increase and counter-clockwise to decrease gas pressure.
- 6/ Reset the pressure regulator cap, close off the gas inlet, remove the manometer tube and put the binding screw back in (F).

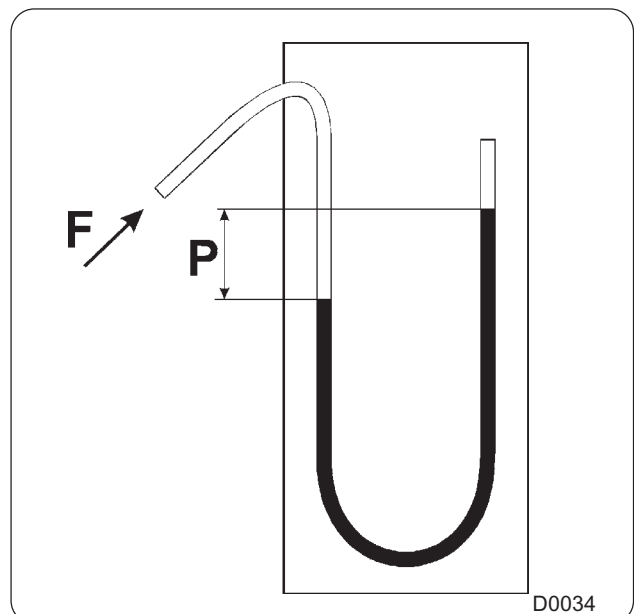

Legend of symbols used

- I: machine working with only one gas family
- II: machine working with two gas families
- 1: 1st family : caol gas or town gas (for information : not used here)
- 2: 2nd family : natural gas
- 3 : 3th family : liquefied petroleum gas (LPG)
- H : natural gas with high calorific value (type G20)
- L : natural gas with low calorific value (type G25)
- E : natural gas with high and low calorific value (type G20)
- LL : natural gas with low calorific value (type G25)
- Esi : natural gas with high and low calorific value with adjustment (type G20)
- B : butane gas (type G30)
- P : propane gas (type G31)
- B/P : butane and propane gas (type G30 and G31)
- 3+ : butane/propane gas with couple of pressure 30/37 (type G30 and G31)

- | | | |
|---------------------|--------------------|------------------|
| AT : Austria | ES : Spain | IT : Italy |
| BE : Belgium | FI : Finland | LU : Luxemburg |
| CH : Switzerland | FR : France | NL : Netherlands |
| CZ : Czech Republic | GB : Great Britain | NO : Norway |
| DE : Germany | GR : Greece | PT : Portugal |
| DK : Denmark | IE : Ireland | SE : Sweden |

- Qn (Hi) : nominal heat emission express in relation to the net calorific value
- Mn : nominal mass (for butane/propane gas)
- Vn : nominal volume (for naturel gas)

For safety reasons use only original spare parts.



TYPE : _____
 SERIAL N° : _____
 QC N° : _____
 PROD. N° : _____
 CAPACITY : _____ l ; _____ kg
 P. MAX. : _____ W
 (M) _____ kW ISOL. CLAS : _____
 _____ W
 _____ V ~ _____ Hz
 _____ A

 Qn (Hi) : _____ kW
 G _____ mbar
 Mn/Vn : _____ / _____
 Type : _____

 G20 - _____ mbar
 G25 - _____ mbar
 G30 - _____ mbar
 G31 - _____ mbar
 η : _____

 P. max. : _____ kPa

CE _____ IP 24 D Date : ____/____/____

ELECTROLUX LAUNDRY
 SYSTEMS FRANCE
 10430 Rosières-près-Troyes
 FRANCE
 Made in FRANCE

32101642

| Country | Category | Gas | Pressure (mbar) |
|--------------------------|----------------|----------------|-----------------|
| AT | I2H | G20 | 20 |
| DE | I2E I3P | G20 G31 | 20 50 |
| BE | I2E(S)B I3P | G20/G25 G31 | 20/25 37 |
| DK-FI-SE-IT | I2H | G20 | 20 |
| FR | II2ESI3P | G20/G25 G31 | 20/25 37/50 |
| CH-CZ-ES- GB-GR-IE-PT | II2H3P | G20 G31 | 20 37 |
| ES-CH | II2H3P | G20 G31 | 20 50 |
| NL | II2L3P | G25 G31 | 25 50 |
| LU | I2E | G20 | 20 |

TABLE OF CORRESPONDENCES - IC43316

| Categorie index | Type of gas | Working supply pressure in mbar | Hi | Ø of injectors in mm | Pressure at injectors in mmH ₂ O | Heat emission Qn in kW (Hi) | Consumption Mn in kg/h | Consumption Vn in m ³ /h |
|-----------------|-------------|---------------------------------|-------------------------|----------------------|---|-----------------------------|------------------------|-------------------------------------|
| *2E, 2H, 2ESI | G 20 | 20 | 34,02 MJ/m ³ | 2.30 | 112 | 20 | - | 2,115 |
| 2L, 2ESI | G25 | 25 | 29,25 MJ/m ³ | 2.30 | 142 | 20 | - | 2,459 |
| 3 + | G30 | 28-30 | 45,65 MJ/kg | 1,4 | - | 20 | 1,58 | - |
| | G31 | 37 | 46,34 MJ/kg | 1,3 | - | 20 | 1,55 | - |
| 3 B / P | G30 | 50 | 45,65 MJ/kg | 1,10 | - | 20 | 1,58 | - |
| | G31 | 50 | 46,34 MJ/kg | 1,10 | - | 20 | 1,55 | - |
| 3 B / P | G30 | 30 | 45,65 MJ/kg | 1,4 | - | 20 | 1,58 | - |
| | G31 | 30 | 46,34 MJ/kg | 1,4 | - | 20 | 1,55 | - |
| 3 P | G31 | 50 | 46,34 MJ/kg | 1,20 | - | 20 | 1,55 | - |

* For Belgium, no work is allowed between G20 and G25.

t0134

TABLE OF CORRESPONDENCES - IC43320

| Categorie index | Type of gas | Working supply pressure in mbar | Hi | Ø of injectors in mm | Pressure at injectors in mmH ₂ O | Heat emission Qn in kW (Hi) | Consumption Mn in kg/h | Consumption Vn in m ³ /h |
|-----------------|-------------|---------------------------------|-------------------------|----------------------|---|-----------------------------|------------------------|-------------------------------------|
| *2E, 2H, 2ESI | G 20 | 20 | 34,02 MJ/m ³ | 2,70 | 97 | 25 | - | 2,64 |
| 2L, 2ESI | G25 | 25 | 29,25 MJ/m ³ | 2,70 | 117 | 25 | - | 3,07 |
| 3 + | G30 | 28-30 | 45,65 MJ/kg | 1,5 | - | 25 | 1,97 | - |
| | G31 | 37 | 46,34 MJ/kg | 1,5 | - | 25 | 1,94 | - |
| 3 B / P | G30 | 50 | 45,65 MJ/kg | 1,30 | - | 25 | 1,97 | - |
| | G31 | 50 | 46,34 MJ/kg | 1,30 | - | 25 | 1,94 | - |
| 3 B / P | G30 | 30 | 45,65 MJ/kg | 1,5 | - | 25 | 1,97 | - |
| | G31 | 30 | 46,34 MJ/kg | 1,5 | - | 25 | 1,94 | - |
| 3 P | G31 | 50 | 46,34 MJ/kg | 1,40 | - | 25 | 1,94 | - |

* For Belgium, no work is allowed between G20 and G25.

t0134

Note :

- G20 (H) = naturel gas, Lacq type (20 mbar)
- G25 (L) = naturel gas, Groningue type (20 or 25 mbar)
- G30 = butane gas (28/30, 50 mbar)
- G31 = propane gas (28/30, 37, 50 mbar)

| | | | |
|----------|------|------|---|
| 01103020 | 0904 | 15 | 5 |
| Notice | Date | Page | |



IMPORTANT

Tightness test after installation

The gas leak test is performed as follows:

1/ Paint pipe joints, pilot gas tubing connections and inspect outlets with rich soap and water solution; do not use an aggressive soap.

2/ Put the machine into service. Bubbles indicate a gas leak.

3/ Eliminate this leak.

Connection of the ironer evacuation system

Fresh air inlet

To allow the dryer ironer to work at its best, it is important that the laundry air inlet passes through an opening from the outside.

The fresh air arrival must be equivalent to the volume of evacuated air (please refer to the output of the fans at zero pressure in the technical characteristics).

Note: in the case of several machines, these values should be added together. In order to prevent drafts in the room, the best solution is to place the air inlet behind the machine.

In the case of a machine with gas heating, it is essential that the rooms should be ventilated.

The free section of the air inlet must be 5 times greater than the section of the evacuation pipe.

Do not forget to allow for the fact that grills often occupy half the total area of the free air opening.

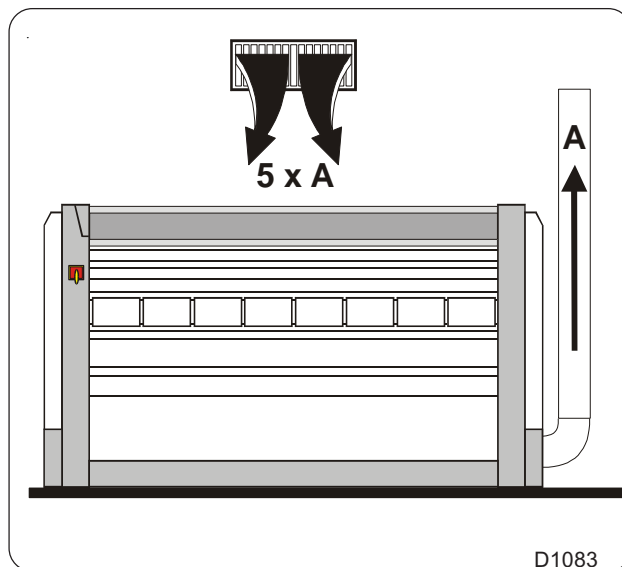

Evacuation duct

It is recommended that a separate smooth-walled evacuation duct should be connected to each dryer, providing the least possible resistance to air.

Check that the shaft flow is at least twice the capacity of the ironer exhaust fan.

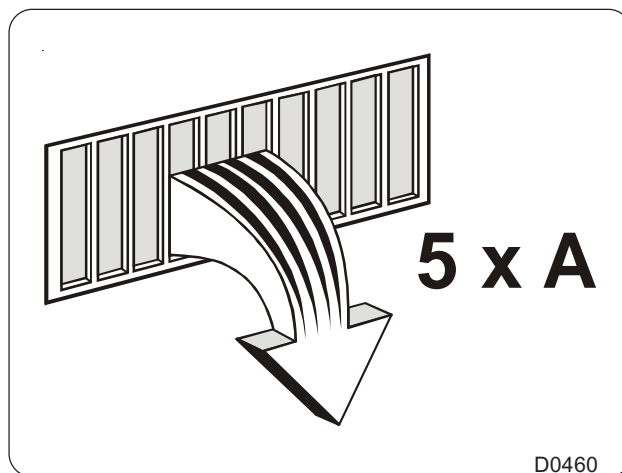

To prevent any risk of burnings, the vapours' evacuation duct of the flatwork ironers of the linen has to be temperature insulated (to be done by the customer).



It is essential that the diameter of the evacuation pipe should be selected as a function of each installation so that the pressure loss never exceed 200 Pa (0.029 psi) (value measured at ambient temperature).

These conditions are **ABSOLUTELY ESSENTIAL** for correct working of the ironer.

CAUTION

The machine should be installed in conformity with the regulations and standards enforced and situated in a correctly ventilated room.

Connect the vapour exhaust nozzle with the flexible pipe (\varnothing 125 mm / 5") and the two collars to your flue.

The vapour exhaust must be separated from any other shaft, as direct as possible and installed according to diagram D0252 (see previous page).

Check that the shaft flow is at least twice that of the exhaust fan.

These conditions are absolutely essential for the correct working of the machine.

Fan maximum flow rate with no pressure :

- 426 m³/h (250 cfm) for a IC43316 machine.
- 515 m³/h (303 cfm) for a IC43320 machine.

Maximum pressure available with no flow : 54 mm H₂O (2.2 inH₂O).

Maximum admissible head loss on evacuation : 20 mm H₂O (0.8 inH₂O).

WARNING : the diameter of the vapour, gas or electrical exhaust pipe must be calculated for each installation in order to avoid pressure drop higher than 20 mm H₂O (0.8 inH₂O).

Average temperature of exhaust coming out of machine : 64 °C (150 °F) for electric heating.

Average temperature of exhaust and products of combustion coming out of machine : 95 °C (200 °F) for gas heating.

Provide an **upper ventilation of 7 dm² (108 sq. in)** and a **lower one of 14 dm² (217 sq. in)** in your laundry.

The fresh air supply area should be five times that of the vent pipe.

In case of gas heating, the fresh air rate requested for the combustion air supply should be not less than 2 m³/h (1.2 cfm) per kW,

- either 40 m³/h (24 cfm) minimum for a IC43316 machine.
- or 50 m³/h (30 cfm) minimum for a IC43320 machine.

The duct must lead to the outside and must be fitted with protection against the weather and foreign bodies.

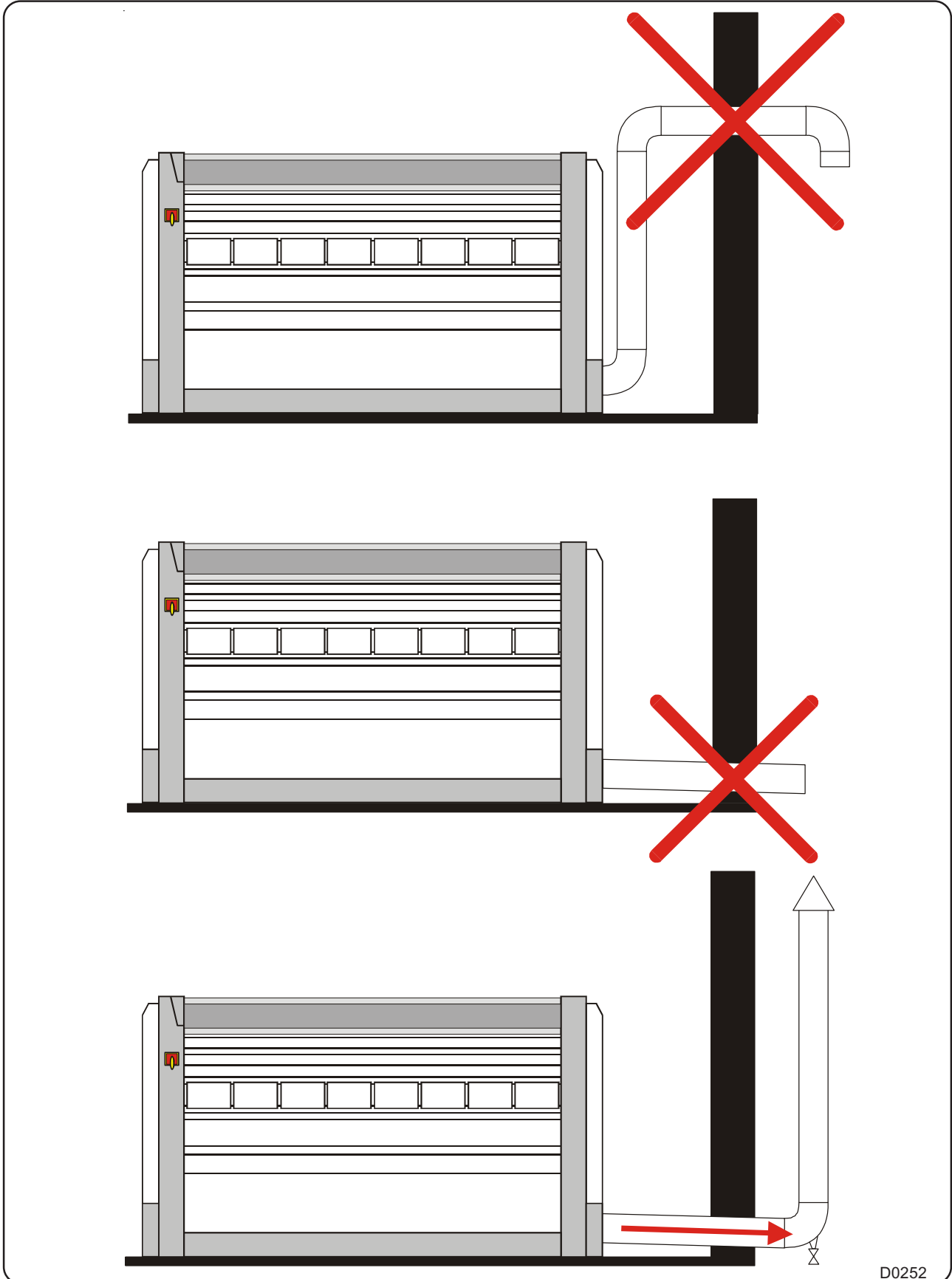

Evacuation system if several dryers are connected to a common evacuation duct (except for the gas heating machines).

If several dryer ironers are installed with a common evacuation duct, the cross-section of the evacuation duct must increase as a function of the number of installed machines so that each of them operates at the same value of air resistance.

Use elbows (and not Tees) to allow the air to pass forwards.

The simplified figure below shows the principle on which the evacuation duct shape is designed.

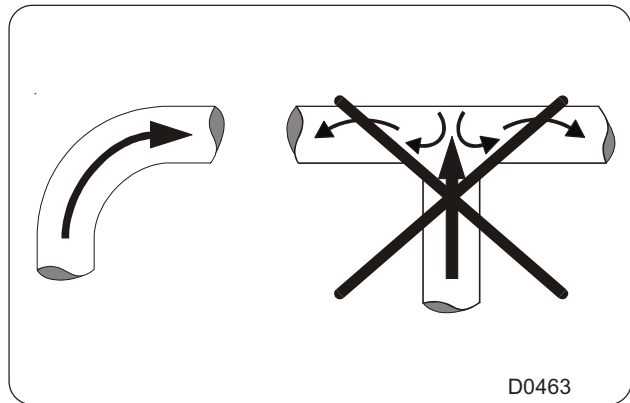

D0463

Number of ironers

Outlet diameter of the exhaust pipe (mm)

D1 D2 D3 D4

125 160 225 315

4.92" 6.30" 8.86" 12.40"

Outlet section of the exhaust pipe

1.25 dm² 2.5 dm² 4 dm² 8 dm²

1346 f² 2691 f² 4306 f² 8612 f²

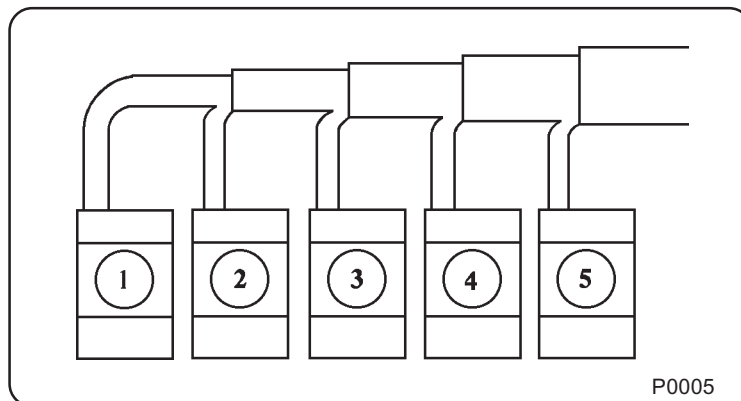

P0005

The indicated evacuation diameter is the dryer outlet diameter.

Please call us if you are in any doubt about the layout of your exhaust device if you are modifying an existing installation.

Operating inspection

The operating inspection must be done by an approved technician.



WARNING

Always make sure that the fan is rotating in the right direction.

The fan must rotate in the direction shown on the arrow glued inside the right compartment (see illustration).

Check the direction of rotation of the fan and the arrow indicating the direction of rotation on the fan.

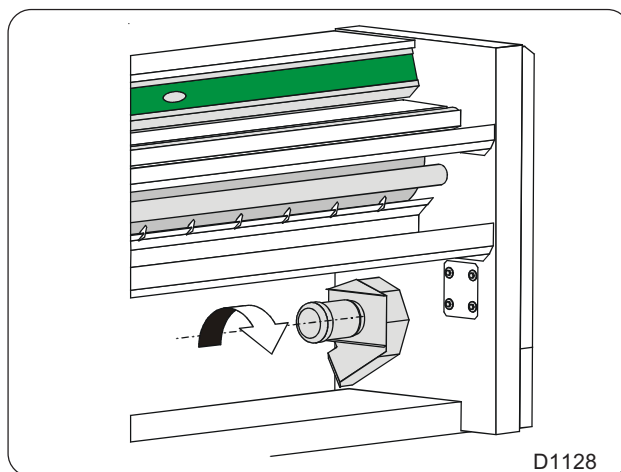

D1128

If it is rotating in the wrong direction, invert two of the three phases on the power supply isolating switch to reverse the direction of rotation of the fan.

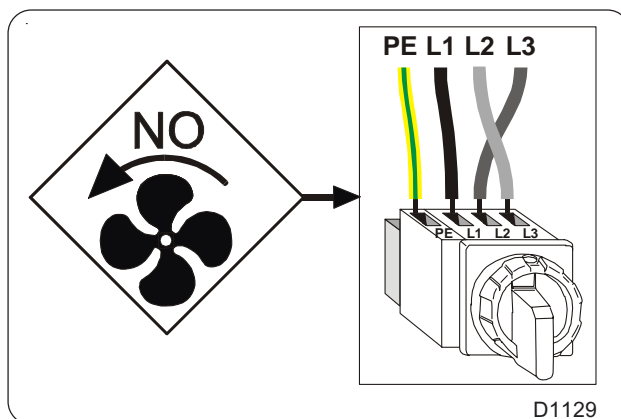

D1129

Check again the direction of the rotation of the fan then replace the hose and its collar.



D0573

| | | | |
|----------|------|------|----------|
| 01103020 | 0904 | 2 | 6 |
| Notice | Date | Page | |



Check-out

Before leaving, put the appliance into operation and allow to run a complete cycle. Watch to ensure that all burner system components function correctly.

Conversion of measurement units

The following is a list of correspondences of the main frequently used units, to avoid the need to use measurement unit conversion tables.

| | | |
|---|--|--|
| bar : | 1 bar = 100 000 Pa 1 bar = 1.019 7 kg/cm ² 1 bar = 750.06 mm Hg 1 bar = 10 197 mm H ₂ O 1 bar = 14.504 psi | 1 kg/cm ² = 0.980 665 bar 1 kg/cm ² = 10 000 mm H ₂ O 1 kg/cm ² = 735.557 6 mm Hg |
| british thermal unit : | 1 Btu = 1 055,06 J 1 Btu = 0.252 1 kcal | pound : 1 lb = 453.592 37 g |
| calorie : | 1 cal = 4.185 5 J 1 cal = 10 ⁻⁶ th 1 kcal = 3.967 Btu 1 cal/h = 0.001 163 W 1 kcal/h = 1.163 W | meter : 1 m = 1.093 61 yd 1 m = 3.280 83 ft 1 m = 39.37 in |
| continental horse-power : | 1 ch = 0.735 5 kW 1 ch = 0.987 0 HP | cubic meter : 1 m ³ = 1 000 dm ³ 1 m ³ = 35.314 7 cu ft 1 dm ³ = 61.024 cu in 1 dm ³ = 0.035 3 cu ft |
| cubic foot : | 1 cu ft = 28.316 8 dm ³ 1 cu ft = 1 728 cu in | pascal : 1 Pa = 1 N/m ² 1 Pa = 0.007 500 6 mm Hg 1 Pa = 0.101 97 mm H ₂ O 1 Pa = 0.010 197 g/cm ² 1 Pa = 0.000 145 psi 1 MPa = 10 bar |
| cubic inch : | 1 cu in = 16.387 1 dm ³ | psi : 1 psi = 0.068 947 6 bar |
| foot : | 1 ft = 304.8 mm 1 ft = 12 in | thermie : 1 th = 1 000 kcal 1 th = 10 ⁶ cal 1 th = 4.185 5 x 10 ⁶ J 1 th = 1.162 6 kWh 1 th = 3 967 Btu |
| gallon (U.K.) : | 1 gal = 4.545 96 dm ³ or l 1 gal = 277.41 cu in | watt : 1 W = 1 J/s 1 W = 0.860 11 kcal/h |
| gallon (U.S.A.) : | 1 gal = 3.785 33 dm ³ or l 1 gal = 231 cu in | watt-hour : 1 Wh = 3600 J 1 kWh = 860 kcal |
| horsepower : | 1 HP = 0.745 7 kW 1 HP = 1.013 9 ch | yard : 1 yd = 0,914 4 m 1 yd = 3 ft 1 yd = 36 in |
| inch : | 1 in = 25.4 mm | temperature degrees : 0 °K = -273.16 °C 0 °C = 273.16 °K t °C = 5/9 (t °F-32) t °F = 1.8 t °C + 32 |
| joule : | 1 J = 0.000 277 8 Wh 1 J = 0.238 92 cal | |
| kilogramme : | 1 kg = 2.205 62 lb | |
| kilogramme per square centimeter : | 1 kg/cm ² = 98 066.5 Pa | |

Thinking of you
 **Electrolux**

www.electrolux.com/laundrysystems

Share more of our thinking at www.electrolux.com