

P 7 + DAMS 9

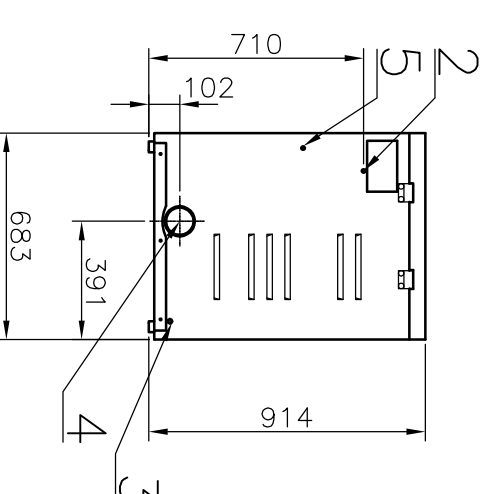

- LEGEND**
1. Main switch
 2. Main power supply
 3. Gas connection
 4. Exhaust outlet
 5. Earthing connection

DAMT9

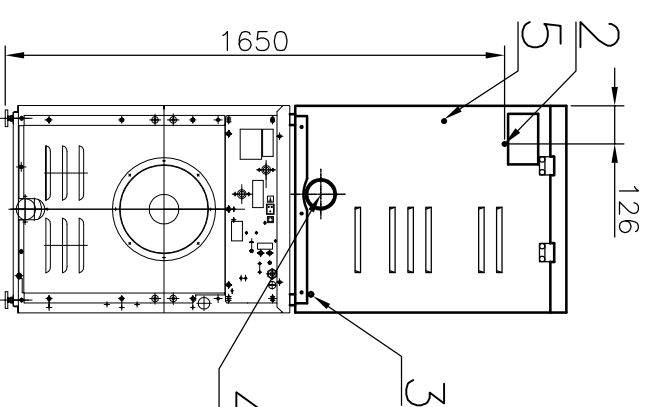
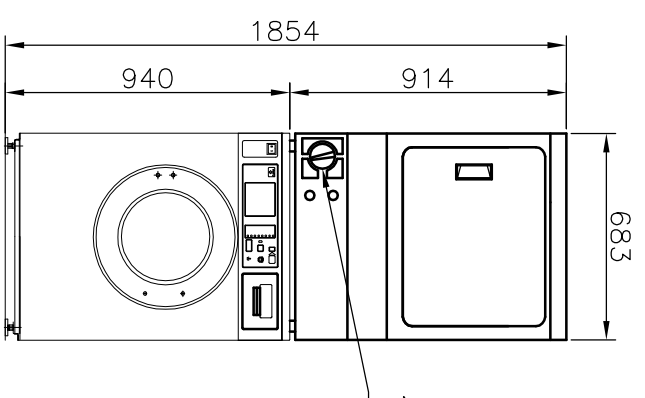
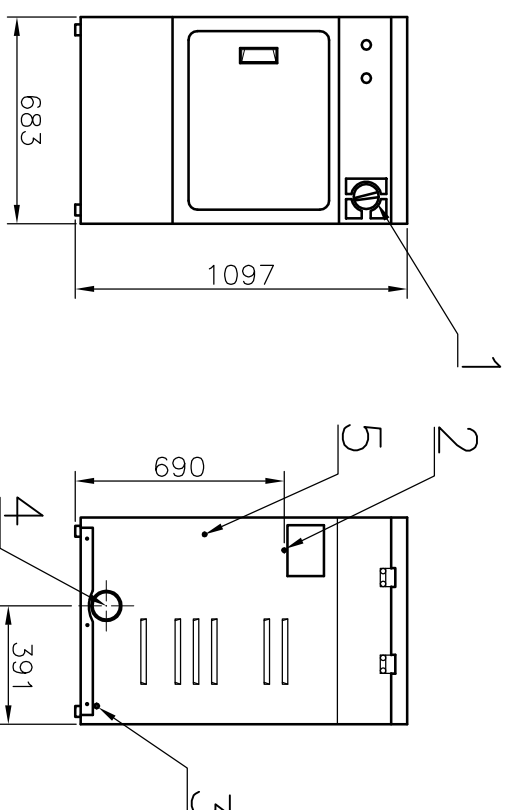

GAS CONNECTION:

Gas installation have to conform to local standards and rules.
 Install upstream of each dryer a manually operated gas shut-off valve on an easily accessible place. Install a dirt and water vapour pipe trap per each dryer gas supply.
 Connect machine supply screwed-fitting and gas shut-off valve through the use of flexible gas hose.
 Gas hoses and gas shut-off valves aren't part of machine delivery.
 Install pressure gauge between pressure reduction valve and manually operated gas shut-off valve because of gas pressure check.

EXHAUST SYSTEM:

The dryer produces hot humid air (maximum temp. 70°C) and combustible lint. To reduce a risk of fire and health problems the dryer must be exhausted to the outdoors by means of exhaust duct connected to exhaust piping.
 The design of the flue system shall be such that any a condensate formed when operating the appliance from cold shall either be retained and subsequently re-evaporated or discharged.
 If possible, do not install dryers and gas fired hot water heaters or the other gravity vented appliances in the same room.
 Use exhaust ducts made of sheet metal or other noncombustible material. Exhaust duct should be practically the shortest.
 Maximum length of 102mm diameter (rigid metal duct / flexible metal duct) in dependence on numbers of 90° elbows:
 0 elbow – 19,8m / 13,7m, 1 elbow – 16,8m / 10,7m, 2 elbows – 14,3m / 9,1m, 3 elbows – 11,0m / 7,6m. Deduct 1.8 m (6') for each additional elbow.
 To prevent backdraft when dryer is not in operation, outer end of exhaust pipe must have a weather hood with hinged dampers.
 The industrial dryer may be located only in ventilated space.
 The dryer requires an action related to air which replaced the air exhausted from the dryer.

MACHINE TYPE	DAMT9, DAMS9
MACHINE DIMENSIONS	
Width – maximum	683 mm
Depth	711 mm
Height – maximum	DAMT 9 1097 mm
	DAMS 9 914 mm
Cylinder – diameter	650 mm
– depth	520 mm
– capacity	184 l
Net weight	57 kg
Exhaust duct diameter	ø102 mm
Optimal air flow quantity	306 m ³ /hour
Equivalent resistance of exhaust duct	98 Pa
GAS	
Gas heating output	6.2 kW
Gas inlet	3/8" NPT
Gas pressure	G20 – 20 mbar
ELECTRICAL DATA	
Rated input power of the machine	0.5 kW
Voltage system	1+PEN 230 V, 50 Hz
Amps	10 A
Conductor section [mm ² Cu]	3x1.5

primus		DAMT9 DAMS9 G		TUMBLE DRYER	
Datum:	25.4.2001	Vykres č.	06-105-2.3		
Autor:	TR	Index/datum	B/05.2009		