

P6 – REAR VIEW

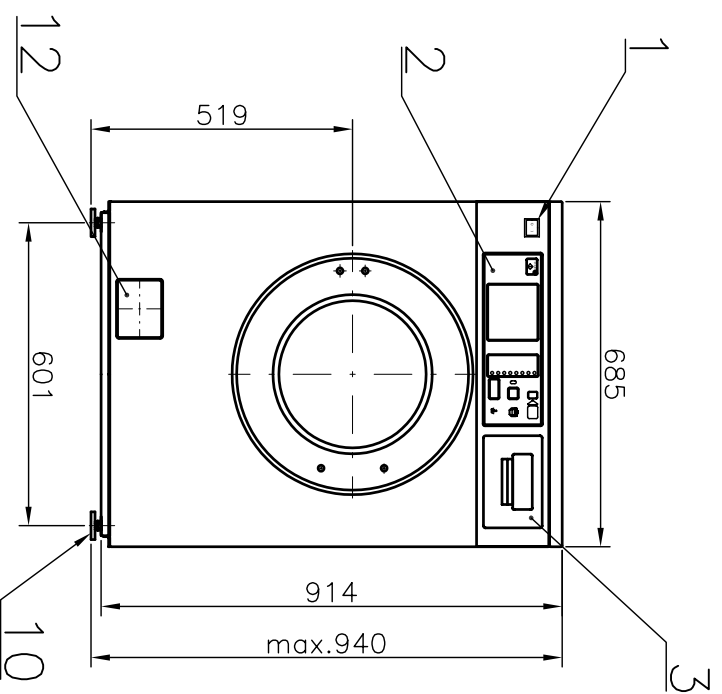

P7 – REAR VIEW

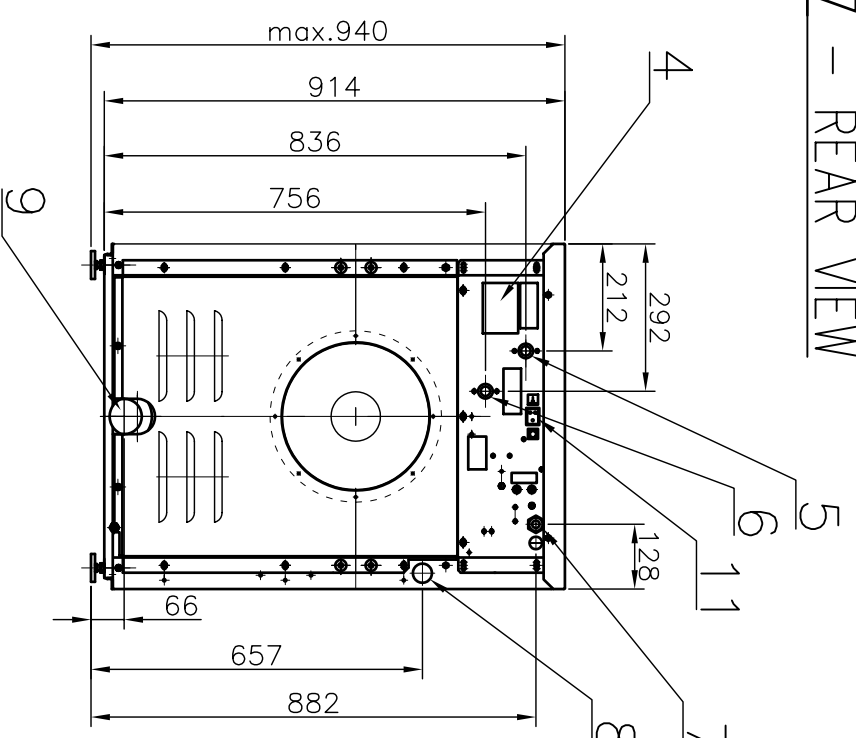
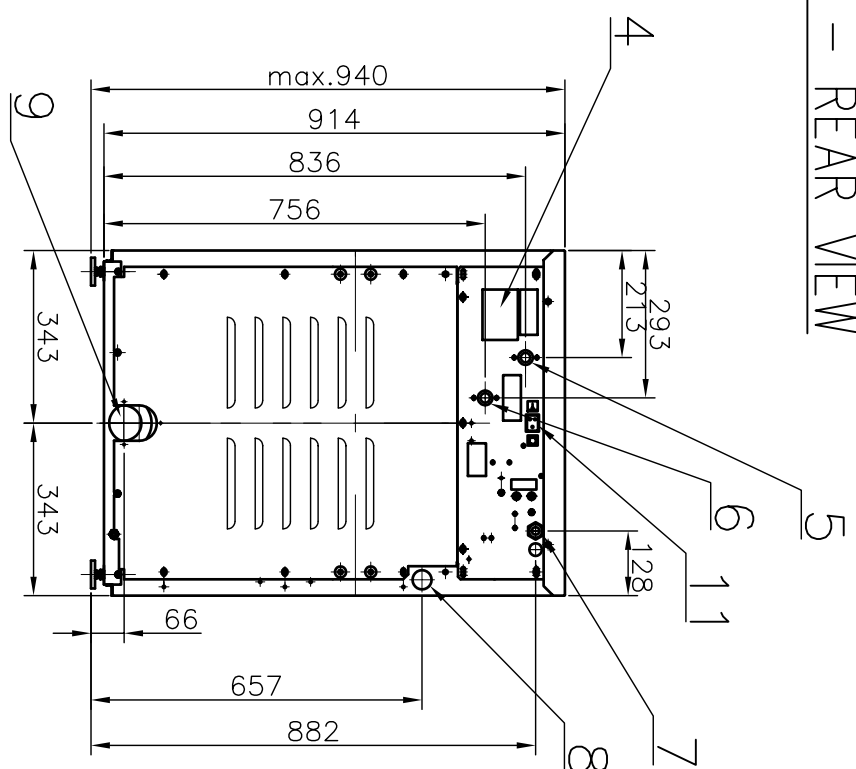

1. Electrical switch
2. EC – microprocessor
3. Soap hopper
4. Serial plate
5. Connection of cold water
6. Connection of hot water
7. Machine electrical connection
8. Drain of the version with drain pump
9. Drain of the version with drain valve
10. Adjustable leg
11. "Program/run" mode push button
12. Pump cover

P7

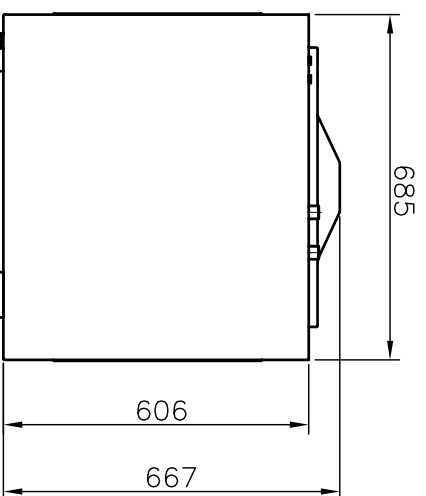

P6

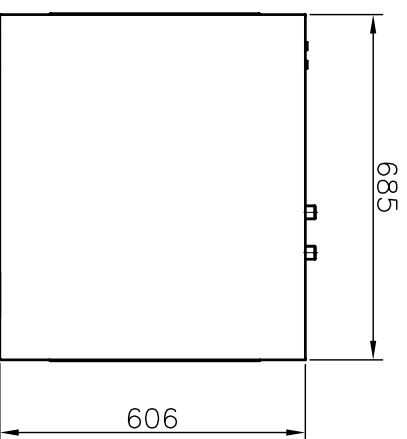

TECHNICAL SPECIFICATION

Type:	P 6	P 7
Capacity: load ratio 1:10	6 kg / 13 lb	7 kg / 15 lb
Inner drum dimensions – diameter – depth	530 mm / 21"	530 mm / 21"
	270 mm / 10.6"	330 mm / 13"
Drum volume	60 dm ³ / 15.8 gal	73 dm ³ / 19.3 gal
Drum revolutions – wash – high extraction	48 rpm	48 rpm
	1150 rpm	1100 rpm
G-factor:	390	360
Machine dimensions (max.) – width – depth – height	685 mm / 27"	685 mm / 27"
	645 mm / 25.4"	685 mm / 27"
	940 mm / 37"	940 mm / 37"
Weight – netto – brutto	165 kg / 364 lb	165 kg / 364 lb
	180 kg / 397 lb	180 kg / 397 lb
Machine electrical system:	3+N+PE ~50Hz 400/230V / TN-S	
Rated motor power:	0.5 kW	0.5 kW
Rated heating power input:	6 kW	6 kW
Rated input power of the machine:	6.5 kW	6.5 kW
Power supply protection:	6kW/3AC 400V/16A	6kW/3AC 400V/16A
Motor overloading protection:	frequency converter protection	
Conductors section:	5x2,5 mm ² Cu	5x2,5 mm ² Cu
Water connection – water pressure – water connection	0.2-0.6MPa / 29-87 psi	0.2-0.6MPa / 29-87 psi
	2x 3/4"	2x 3/4"
Drain connection – drain valve (external diameter) – via drain pump (internal hose diameter)	Ø51 mm / Ø2"	Ø51 mm / Ø2"
	Ø33.5 mm / 1.32"	Ø33.5 mm / 1.32"
Max. static load (with textile and water)	184 kg / 406 lb	198 kg / 437 lb
Anchoring the machine	free locating in horizontal level	

FASTENING THE MACHINE
The machine must be located on a leveled floor which complies static stress of the machine. Check the position of machine top by a water level and adjust machine leg. If the machine is located on a higher base for better operation, the front legs of the machine should be locked for safety reasons.

WATER CONNECTION:
The washer is equipped with 3/4" valves for watering of cold and warm (70°C maximum) water. The all valves have to be connected for right function of washer. The filling valves (3/4") are part of machine. The pressure hoses with seal are part of delivery. Stop valves (3/4") have to be on supply line.

WATER DRAIN CONNECTION:
The machine is equipped with drain valve or optional with pump.
– for the machine equipped with drain valve: connect the drain valve by means of included clamp. The main drain pipe must have the capacity to be able to handle the total output of all connected machines
– for the machine equipped with drain pump: connect the end of the drain hose to a siphon or via a wash – basin / sink. The hose must be laid out without kinks. The end of the hose must be not higher than 100 cm (39") above floor level
Put the stench trap in drain pipe.
The maximum temperature of waste water from washer is 70-80°C (for program No.1 – hot washing).
Quantity of draining water: 6kg washer – 32 l/min, 7kg washer – 42 l/min.

primus

P6
P7

Datum:	25.04.01	No.	01-114-21
Autor:	I.R.	Index/datum	C/01.2007

WASHER EXTRACTOR