

LEGEND

1. Electronic control
2. Control panel lock
3. Emergency stop button
4. Door
5. -
6. -
7. Main switch
8. Main power supply
9. Air outlet
10. Suction
11. -
12. Earthing connection
13. Lint screen cover

EXHAUST SYSTEM:

The dryer produces hot humid air (maximum temp. 70°C) and combustible lint. To reduce a risk of fire the dryer must be exhausted to the outdoors by means of exhaust duct connected to exhaust piping.

The design of the flue system shall be such that any a condensate formed when operating the appliance from cold shall either be retained and subsequently re-evaporated or discharged.

If possible, do not install dryers and gas fired hot water heaters or the other gravity vented appliances in the same room.

Use exhaust ducts made of sheet metal or other noncombustible material.

The dryer requires an action related to air which replaced the air exhausted from the dryer.

Opening(s) for air supply from outside of the building should be as close to the dryer(s) as possible.

Aerating opening(s) for the make-up air supply required per each individual dryer is 0,16 m².

Position on a frame

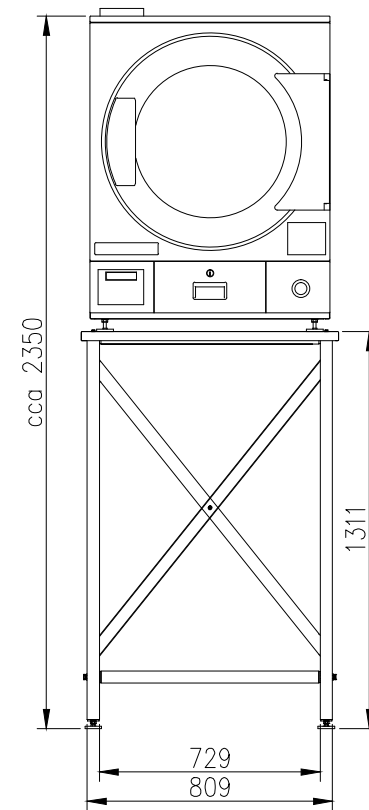

With FS10 washer

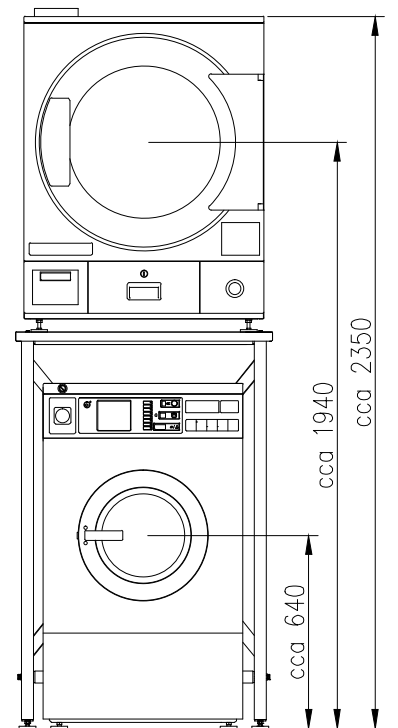

FS10

MACHINE DIMENSIONS	
Width – maximum	795 mm / 31.3"
Depth	1240 mm / 48.8"
Height – maximum	1075 mm / 42.3"
Cylinder – diameter	760 mm / 29.9"
– depth	630 mm / 24.8"
– capacity	285 l
Net weight	185 kg / 408 lbs
Air outlet	~ø200 mm
Optimum air flow	650 m3/hod
Max. static back pressure	150 Pa
ELECTRICAL DATA	
Heating elements	18 kW
Motor input	0.25 kW
Fun input	0.37 kW
Input power	18.7 kW
Voltage system	3+NPE 400 V, 50 Hz
Amps	32 A
Conductor section [mm ² Cu]	4x 6
Sound of pressure level	< 70 dB

primus	TAMS 13 E	Date:	08/2009	No.	06-115-2.1
		Author:	RJ	Index/date	
TUMBLE DRYER					