

HIGH SPIN INDUSTRIAL WASHER EXTRACTORS

**8kg
11kg
14kg**

ORIGINAL INSTALLATION, MAINTENANCE AND USER'S MANUAL

**540889
Publication date: 1 Jul 2011**

Contents

Contents	
Safety precautions	4
Operation	8
Symbols on the machine.....	8
Version Xcontrol, Version Xcontrol Plus.....	9
Before washing	10
Opening the drum door	10
Placing the laundry into the machine.....	10
Closing the drum door.....	10
Program selections	10
Wash programs overview	11
Add detergents.....	11
Start the washer	12
Version Xcontrol.....	12
Version Xcontrol Plus.....	13
End of wash cycle	13
Power cut	13
Version Xcontrol.....	13
Version Xcontrol Plus.....	13
How to open the door by failure.....	13
First service at technical problem	14
Technical data	16
Connections	16
Machines 8-11-14 kg / 18-25-30 lb	17
Installation	20
Transportation and unpacking	20
Siting and floor	21
Mechanical installation.....	22
Water connections	23
Drain connection	25
Venting.....	26
Liquid soap connection	26
Electrical connection	27
Electronic controller with blue pcb and graphical display	27
Electrical installation	28
General	28
Residual current device (RCD)	29
Supply protection device.....	29
Supply cable	29
Machine protective earth connection and equipotential bonding.....	30
Multiple machines in line single phase	31
Maintenance and adjustments	32
Checking and maintenance daily.....	32
Checking and maintenance every three months	32
Checking and maintenance every six months	33
Replacement of door rubber.....	34
Adjusting of out of balance switch	34
Belt replacement and adjusting tension.....	34
Water filters.....	34
Tightening moments	35
Replacement washer fuses	35
Trouble shooting aids	36
Unblocking of the door lock in case of emergency	36
Error indication shown on display	36
List of recommended spare parts	37

Safety Precautions

Safety precautions



WARNING - SAVE THESE INSTRUCTIONS FOR LATER USE.

Failure to comply with the instructions may lead to incorrect use of the appliance, and may result in risk of fire, bodily injuries or death and/or damage to the laundry and/or the appliance.



WARNING - Read the IMPORTANT SAFETY INSTRUCTIONS in this manual carefully before operating the appliance. Improper use of the appliance may cause risk of fire, electrical shock or serious body injuries or death as well as serious damage to the appliance.

- ◆ This English version is the original version of this manual. Without this version, the instructions are incomplete.
- ◆ Before installation, operation and maintenance of the machine read carefully the complete instructions, i.e. this "Installation, maintenance and user's manual", "Programming manual" and "Spare parts manual".
The Programming manual and Spare parts manual are not delivered with a machine by default. You shall ask the supplier / manufacturer to obtain Programming manual and Spare parts manual.
- ◆ Follow the instruction written in manuals and keep the manuals in a proper place by the machine for later use.
- ◆ Safety instructions included in manuals for personnel operating the appliance must be printed and posted on a visible place near the machine in the laundry room.
- ◆ The washer extractor is designed for fabrics washing only, other objects can damage the washer and can cause damage or injuries.
- ◆ If the machine is used for special applications follow the instructions and warning to avoid person injury.
- ◆ The manufacturer is not responsible for the damage to the fabrics that are washed by an inappropriate washing method.
- ◆ Always follow the instructions and/or warnings that are stated on the fabrics, washing products or cleaning products mentioned by the manufacturer.
- ◆ The washer must be set up in accordance with the instructions. All drain, inlet, electrical connections, ventilation, groundings and other connections must be done in according to the installation manual, in compliance with the local standards done by qualified technicians with proper authorization.
- ◆ The valid standards for connecting to the local power network (TT, TN, IT, ...) must be followed.
In the standard execution, the appliance may not be suitable for connecting to an IT supply system.
Contact your commercial distributor for assistance.
- ◆ All appliances are produced according the EMC-directive (Electro-Magnetic-Compatibility). They can be used in restricted surroundings only (comply minimally with class A requirements). For safety reasons there must be kept the necessary precaution distances with sensitive electrical or electronic device(s).
- ◆ Do not change the parameters of the frequency inverter. This can cause serious injury, fire, washer damage, etc.
- ◆ During transportation and storage never use excessive forces on the packing because components can be damaged protruding the contour line of the appliance.
- ◆ Use copper conductors only. This appliance must be connected to a supply circuit to which no lighting units or general-purpose receptacles are connected.
- ◆ Any changes concerning the installation which are not described in this Installation Manual must be approved by the supplier or manufacturer. Otherwise, the supplier and manufacturer are not responsible for potential injuries to operators or for any damages. Interventions in the appliance execution or functions are not allowed, and the manufacturer refuses any responsibility in such cases.
- ◆ The washer extractor must be installed on level. If not, the washer may become unbalanced during extraction and, although fitted with an unbalance safety, the washer may become seriously damaged what may result in bodily injuries.
- ◆ Never put the washer in operation when the transporting braces are not removed. The washer should always be tested before use.
- ◆ It is possible that there are residues of products used during the production process in the new washer. These residues could cause stains on your laundry. Therefore, you must first run at least 1 hot wash with old rags before using for your normal laundry.
- ◆ Keep the appliance top and surface and the area around clean and clear of combustible or flammable products.
- ◆ The use of hypochlorite will cause corrosion which may cause component failure under certain circumstances.
- ◆ The warranty of the machine cannot be accepted in case corrosion was caused by chlorine and chlorine compounds impact.
- ◆ The washer extractor is not designed for work which may create an explosive atmosphere inside the machine and will not be used for this purpose.
- ◆ Do not expose the washer extractor to the weather, extreme low or high temperature and humidity.
- ◆ Do not store flammable materials around the appliances. Define the dangerous areas in the laundry room and obstruct an admission to them during appliances operating.

Safety Precautions

- ◆ Do not wash articles that have been previously cleaned in, wash in soaked in, or spotted with gasoline, dry-cleaning solvents, or other flammable or explosive substances as they give off vapors that could ignite or explode. Such fabrics must first be washed by hand and air dried.
- ◆ Do not add gasoline, dry-cleaning solvents, or other flammable or explosive substances to the wash water. These substances give off vapors that could ignite or explode.
- ◆ Under certain conditions, hydrogen gas may be created in the hot water system that has not been used for two or more weeks. HYDROGEN GAS IS EXPLOSIVE. If the hot water system has not been used for such period open all hot water taps and let the water run out for few minutes. This will release any accumulated gas. As this gas is flammable, do not smoke or use open flames during this time.
- ◆ TEMPERATURE IN WASHING MACHINE TUB: The electronic controller uses the temperature sensor in the tub to control the temperature of the washing bath. There are a lot of things that have influence on the temperature measurement. Therefore the temperature control of the washing bath is not very precise.
- ◆ Always strictly comply with the instructions that are written on the laundry chemicals-, laundry aids-, dry-cleaning solvents- and disinfectants packaging to avoid personal injury. Keep these agents out of the reach of children, preferably in a locked cabinet.
- ◆ Do not tamper the washer-extractor controls and do not bypass the safety instructions and the warnings.
- ◆ By danger turn off the main switch or other emergency disconnection devices.
- ◆ Do not put some part on the soap dispenser lid to held it open by filling or when the machine operates. Do not open the soap dispenser lid after the machine is started. The discharge or splashing of hazardous liquid can cause serious scalding and burning.
- ◆ Do not operate the appliance when parts are broken or missing or when covers are open. The appliance must not be operated until the fixed guards are put correctly in place.
- ◆ The appliance must not be stored, installed or exposed to the weather, extreme low or high temperature and humidity levels. Do not hose down the washer. NEVER allow the appliance to get wet.
- ◆ Check the functioning of the door lock mechanism on regular base. NEVER bypass the doorlock mechanism.
- ◆ Disconnect the power and close all water and steam supply before cleaning, servicing and at the end of each operating day.
- ◆ Out of the venting at the back of the washer can escape warm vapor or and hot air. Do not cover the vent but protect it sufficiently. It serves air gap and as a vapor outlet to prevent pressure building in the washer.
- ◆ Do not repair or replace any part of the appliance or attempt any servicing unless specifically recommended in the service manual or published user-repair instructions that you understand and have the skills to carry out. Only qualified service personnel may open the appliance to carry out servicing.
- ◆ Information contained in this manual is intended for use by a qualified service technician familiar with proper and safe procedures to be followed when repairing an electrical appliance. All tests and repairs should be performed by a qualified service technician equipped with proper tools and measuring devices. All component replacements should be made by a qualified service technician using only factory approved replacement parts.
- ◆ Improper assembly or adjustment may occur if service or repair is attempted by persons other then qualified service technicians or if parts other then approved replacement parts are used. Improper assembly or adjustment can create hazardous conditions.
- ◆ There can be a risk of injury or electrical shock while performing services or repairs. Injury or electrical shock can be serious or even fatal. Consequently, extreme caution should be taken while performing voltage checks on individual components or a product. PLEASE NOTE: Except as necessary to perform a particular in servicing a product, the electrical power supply should ALWAYS be disconnected when servicing a product.
- ◆ All industrial (OPL - On Premise Laundry) washers are designed for use in Laundry with professionally trained attendants.
- ◆ Before the appliance is removed from service or discarded, remove the door.
- ◆ Any Water or Steam Leaks Must Be Repaired Immediately. Closed supply immediately.
- ◆ If any problems or failures should arise, immediately contact your dealer, serviceman or manufacturer.
- ◆ The manufacturer reserves the right to change the manuals without previous notice.
- ◆ Norm IEC335 is applied for machines with a net usable cage volume between 60 and 150 l. Norm EN60204-1 is used for a net usable cage volume above 150 l.

Safety Precautions

⚠ WARNING

DO NOT TOUCH THE DOORGLASS UNTIL CYCLE HAS BEEN COMPLETED. DO NOT OPEN DOOR UNTIL CYLINDER REMAINS STOPPED AND WATER HAS BEEN DRAINED FROM CYLINDER. DO NOT PUT ARTICLES SOILED WITH EXPLOSIF SOLVENTS AND/OR DANGEROUS CHEMICAL PRODUCTS IN THE MACHINE. THIS MACHINE SHOULD NOT BE USED BY CHILDREN. DO NOT LET CHILDREN PLAY IN, ON, OR AROUND THE MACHINE. BEFORE TURNING THE MACHINE „ON“, MAKE SURE THAT THERE ARE NO PEOPLE OR ANIMALS PRESENT IN OR AROUND THE MACHINE.

⚠ WARNING

ORIGINAL OR IDENTICAL PARTS MUST BE USED FOR REPLACEMENT IN THIS MACHINE. AFTER SERVICING REPLACE AND SECURE ALL PANELS IN THE ORIGINAL WAY. TAKE THESE MEASURES FOR CONTINUED PROTECTION AGAINST ELECTRICAL SHOCK, INJURY, FIRE AND/OR PROPERTY DAMAGE.

⚠ WARNING

LOOKING AT THE MACHINE FROM THE FRONT VIEW THE DRUM ROTATION DURING EXTRACTION MUST BE CLOCKWISE.

⚠ WARNING

THIS APPLIANCE MUST BE CONNECTED TO A GROUNDED METAL, PERMANENT WIRING SYSTEM, AND ADDITIONALLY AN EQUIPMENT-GROUNDING CONDUCTOR MUST BE RUN WITH THE CIRCUIT CONDUCTORS AND CONNECTED TO THE EQUIPMENT-GROUNDING TERMINAL OR LEAD ON THE APPLIANCE.

⚠ WARNING

IN ORDER TO MINIMIZE THE RISK OF FIRE, ELECTRICAL SHOCK AND INJURY, THIS WASHER MUST BE PROPERLY GROUNDED. NEVER PLUG IN OR DIRECT-WIRE AN APPLIANCE UNLESS IT IS PROPERLY GROUNDED IN ACCORDANCE WITH ALL LOCAL AND NATIONAL CODES. IF MORE APPLIANCES IN THE SAME LOCATION, MUTUAL GROUNDING MUST BE APPLIED WHERE POSSIBLE.

⚠ WARNING

THE WASHER EXTRACTOR IS INTENDED TO BE PERMANENTLY CONNECTED, IT MUST BE SECURED MOUNTED TO A NON-COMBUSTIBLE, ADEQUATE FLOOR STRUCTURE. A CONCRETE FOUNDATION IS REQUIRED. METAL REINFORCED WOOD FLOORS ARE NOT ALLOWED DUE TO THE RISK OF FIRE AND EXCESSIVE VIBRATIONS. NEVER INSTALL THE WASHER ON AN UPPER FLOOR OR OVER A BASEMENT WITHOUT A LOAD SUPPORT DESIGNED BY A STRUCTURAL ENGINEER.

⚠ WARNING

ALTHOUGH THE APPLIANCE MAY BE IN THE “OFF” POSITION, THERE IS STILL ELECTRICAL POWER TO THE SWITCH SUPPLY TERMINALS.

Safety Precautions

⚠ WARNING

WHEN POWER SUPPLY HAS BEEN SWITCHED OFF WAIT FOR AT LEAST 10 MINUTES BEFORE STARTING INSPECTION OR SERVICING THE WASHER. BEFORE STARTING INSPECTION OF FREQUENCY INVERTER, CHECK FOR RESIDUAL VOLTAGE ACROSS MAIN CIRCUIT TERMINALS + AND -. THIS VOLTAGE MUST BE BELOW 30 VDC BEFORE YOU CAN ACCESS THE INVERTER FOR INSPECTION.

⚠ WARNING

DO NOT ALLOW CHILDREN TO PLAY ON, IN OR AROUND THE APPLIANCE AT ANY TIME. CLOSE SUPERVISION OF CHILDREN IS NECESSARY WHEN THE APPLIANCE IS USED NEAR CHILDREN. NEVER PERMIT CHILDREN TO OPERATE THE APPLIANCE.

⚠ WARNING

IF THE DOOR SAFETY LOCK DOES NOT WORK, DO NOT USE WASHER UNTIL THE DOOR LOCK MECHANISM IS REPAIRED.

⚠ WARNING

FOLLOW ALL VALID BASIC SAFETY RULES AND LAWS. THE INSTRUCTIONS IN THIS MANUAL CANNOT ACCOUNT FOR EVERY POSSIBLE DANGEROUS SITUATION. THEY MUST BE GENERALLY UNDERSTOOD. CAUTION AND CARE ARE FACTORS WHICH CAN NOT INCLUDED IN THE DESIGN OF THE APPLIANCE AND ALL PERSONS WHO INSTALL, OPERATE OR MAINTAIN THE APPLIANCE MUST BE QUALIFIED AND FAMILIAR WITH THE OPERATING INSTRUCTIONS. IT IS UP TO THE USER TO TAKE PROPER CARE WHEN OPERATING THE APPLIANCE.

⚠ WARNING

DO NOT REMOVE WARNING SIGNS PLACED ON THE APPLIANCE. OBSERVE SIGNS AND LABELS TO AVOID PERSONAL INJURIES. SAFETY LABELS APPEAR AT CRUCIAL LOCATIONS ON THE APPLIANCE. FAILURE TO MAINTAIN LEGIBLE SAFETY LABELS COULD RESULT IN INJURY TO THE OPERATOR OR SERVICE TECHNICIAN.

⚠ WARNING

IF THE INSTALLED APPLIANCE OPERATE WITH COIN, TOKEN OR SIMILAR OPERATION FOR USE IN SELF-SERVICE SITUATIONS, THEN THE OWNER-INSTALLER MUST PROVIDE A REMOTE-LOCATED EMERGENCY STOP DEVICE. THIS DEVICE MUST BE PLACED IN SUCH A WAY THAT IT IS EASY AND SAFELY ACCESSIBLE FOR THE USERS. THE EMERGENCY STOP DEVICE TAKES CARE THAT AT LEAST THE CONTROL CIRCUIT OF THE APPLIANCE IS INTERRUPTED.

Operation

Operation

Symbols on the machine



Caution, dangerous electrical tension, electrical devices



Caution, other danger, read and follow written instructions



Caution - Increased temperature



Do not close or cover



The machine hot air outlet



In case of emergency press the emergency button to stop the machine

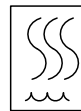

Steam

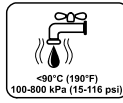

Warm water inlet
(red color of the label)

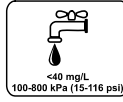

Soft cold water inlet
(light blue color of the label)

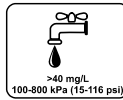

Hard cold water inlet
(dark blue of the label)









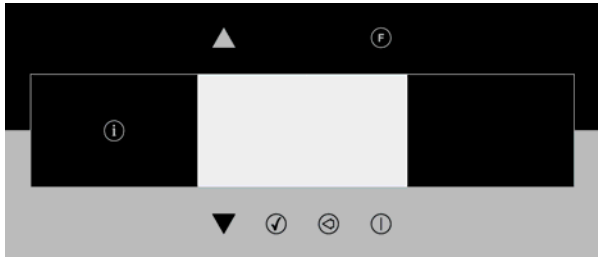

The holes to be drilled not punched

531400

Operation









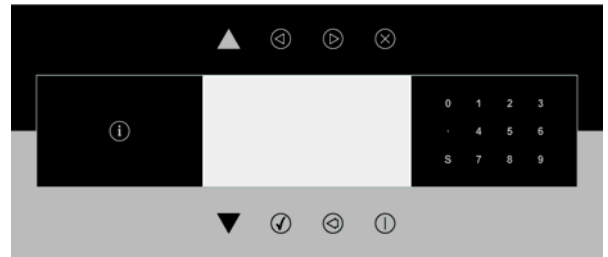

Version Xcontrol



-  **START**
(ADVANCE function for the **OPL version**) (1)
-  **CONFIRM THE SELECTION**
-  **CANCEL THE SELECTION**
-  **MOVE UP**
-  **MOVE DOWN**
-  **SELECTION OF ADDITIONAL FUNCTIONS**
-  **INFO**
OPL version: program information
Coin operated version: User's Manual

Version Xcontrol Plus



-  **START**
(ADVANCE function)
-  **STOP** (program interruption)
-  **CONFIRM THE SELECTION**
-  **CANCEL THE SELECTION**
-  **MOVE UP**
-  **MOVE DOWN**
-  **DECREASING THE TIME SEQUENCE**
-  **INCREASING THE TIME SEQUENCE**
-  **INFO**
(overview of available wash programs and program information)
-  **SERVIS** (servicing information)
-  **DELAYED START FUNCTION**
(the delay starts running upon the pressing of the "start" button)
- 0 to 9** **NUMERIC KEYPAD**

(1) **OPL** version - washers are designed for professionally trained attendants.

Operation

Before washing

Sort the linen according on the temperature and the instructions of the manufacturer of the fabrics. Check if there aren't any strange objects between the linen like nails, screws, needles, etc. in order not to damage the washer-extractor or the linen. Turn sleeves of shirts, blouses, etc. inside out. To get a better washing result, you have to unfold the fabrics and mix the bigger and smaller pieces of fabrics.

Opening the drum door

Open the door by pulling on the door handle.

Placing the laundry into the machine

CAUTION!

The optimal washing load is determined by the filling factor. The proper filling factor is determined by the type of linen and other factors. Cotton textiles normally require a filling factor of 1:10-1:13, which is a full drum load. Put the linen in the drum depending on the maximum capacity of the washer. Do not overload the washer extractor. Overloading the machine can lead to a bad wash result. Half washing loads can obstruct a proper function. Synthetics and blended fabrics usually require a filling factor of 1:18-1:20, which is half drum load. Loading more will reduce the wash result and can damage the linen.

Closing the drum door

Close the door with the door handle, making sure the door is properly latched before operating the washer.

Program selections

Choose one of the available wash programs, best corresponding to the quality of the garments and allowed wash temperature in the wash load.

The **Xcontrol** version : choose the wash program by the arrow buttons "▲ up" and "▼ down".
The **Xcontrol Plus** version : enter the wash program number utilizing the numeric keypad.

The selection of the program determines the temperature and the time for washing and rinsing.

NOTE!

For locking a program mode, changing factory settings and possibilities of program changes and setup - see Programming manual.

Operation



Wash programs overview

Wash program 1	Hot wash intensive	90°C	
Wash program 2	Warm wash intensive	60°C	
Wash program 3	Coloured wash intensive	40°C	
Wash program 4	Bright wash intensive	30°C	
Wash program 5	Woollens	15°C	
Wash program 6	Hot wash	90°C	ECONOMY level
Wash program 7	Warm wash	60°C	ECONOMY level
Wash program 8	Coloured wash	40°C	ECONOMY level
Wash program 9	Bright wash	30°C	ECONOMY level
Wash program 10	Eco hot wash	90°C	ECONOMY level
Wash program 11	Eco warm wash	60°C	ECONOMY level
Wash program 12	Eco color wash	40°C	ECONOMY level
Wash program 13	Eco bright wash	30°C	ECONOMY level
Wash program 14	Extraction		low speed
Wash program 15	Extraction		high speed
Only Xcontrol Plus: Wash program 16	Sport	60°C	
Only Xcontrol Plus: Wash program 17	Mops	60°C	
Only Xcontrol Plus: Wash program 18	Horse cloths	40°C	
Only Xcontrol Plus: Wash program 19	Jeans	60°C	
Only Xcontrol Plus: Wash program 20	Starching	-	

Add detergents

Fill the soap dispenser on the top of the washer extractor depending of the chosen program.



- Pre-wash in the soap dispenser  : detergent for the pre-wash.
- Main wash in the soap dispenser  : detergent for the main wash.
- Main wash in the soap dispenser  : liquid detergent for the main wash or liquid bleach etc.
- Fabric softener or starch in the soap dispenser  : fabric softener or starch for the last rinse.

NOTE!

It is advisable to use only detergents with „foam breaker“, which can easily be found in retail shops. The dosage of soap to use is generally mentioned on the packing. An overdose of detergent can lead to poor wash results and „suds“, overflow which can damage the machine.

Take care that the lid of the soap dispenser is closed if the machine starts.

Operation

Start the washer

Version Xcontrol

Coin operated models

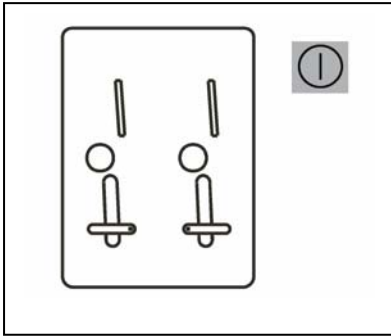

- Choose the required wash program. Insert the correct amount of coins in the slot - the sum must correspond to the selected program. The display shows the remaining sum to be paid. After the payment is done, the display prompts the user to start the program utilizing the **START** button.
- Push the **START** button to start the washer extractor. If you have by mistake chosen a different wash program, you can change the choice within the first 150 seconds utilizing the arrow buttons "▲ up" and "▼ down". When a more expensive washing program was chosen, the value will be shown to add. When you don't add more coins, the chosen program at the start will be executed.
- During the washing cycle you can follow the actual washing sequence and the remaining time on the displays.

Non-coin operated models

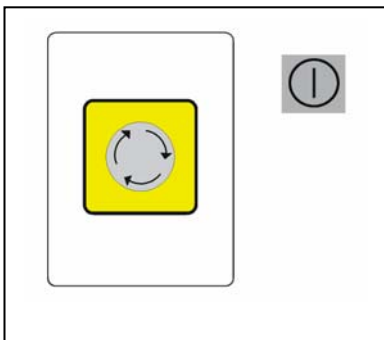

- Choose the required program. Press the **START** button to start the operation of the machine. If you have by mistake chosen a different wash program, you can change the choice within the first step utilizing the arrow buttons "▲ up" and "▼ down".
- During the washing cycle you can follow the actual washing sequence and the remaining time on the displays.
- If the machine operator has enabled the **ADVANCE** function, you can move to the next step by pressing the **START** button.

Operation

Version Xcontrol Plus

After you have selected the required wash program, start the wash cycle by pressing the **START** button. If you enter a number that does not correspond to any of the available programs, the display shows the message **INVALID**. During the wash cycle the user can follow the progress of the wash sequence and the remaining wash cycle time on the display.

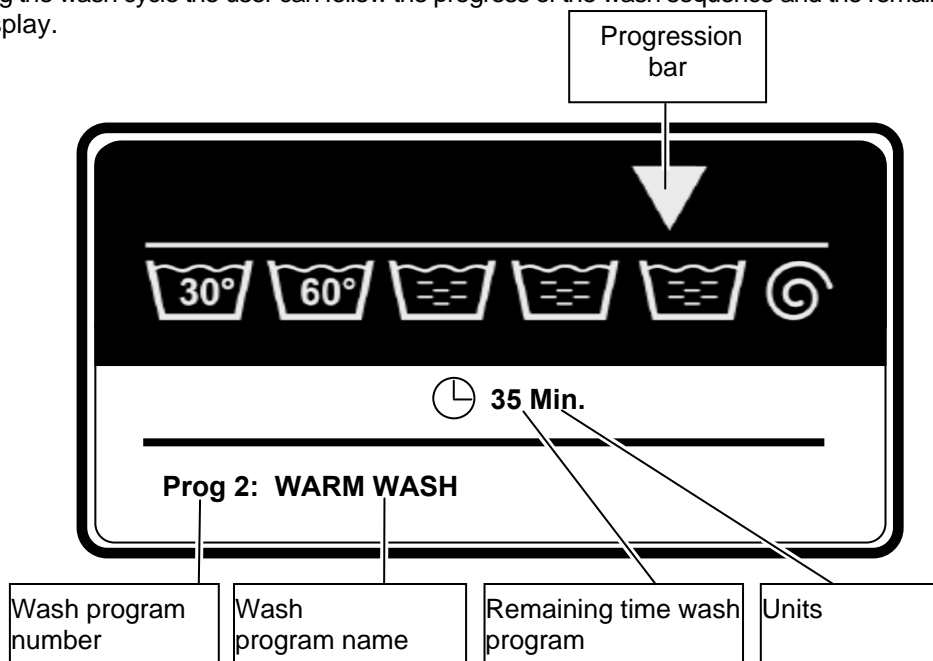

End of wash cycle

The wash cycle time is counted down to zero on the display. After the completion of the wash cycle, the door lock gets deactivated (it unlocks) and the display shows the message **UNLOAD**. Open the door and remove the laundry from the machine. The message **UNLOAD** disappears and the machine is ready to start a new program. The **SELECT CYCLE** option is displayed.

⚠ WARNING!
IF, AFTER A POWER CUT, THE MACHINE DOOR CANNOT BE OPENED AND THE MACHINE IS FITTED WITH AN AUTOMATIC UNLOCKING CIRCUIT, WAIT UNTIL THE UNLOCKING CIRCUIT UNLOCKS THE DOOR LOCK. BEFORE YOU OPEN THE DOOR, MAKE SURE THAT THE DRUM IS COMPLETELY STILL AND THAT THE WATER HAS DRAINED FROM IT.

Power cut

Version Xcontrol

If a power cut occurs and the door is closed and locked, the wash program will, after the power supply has been restored, automatically continue in the program beginning from the step in which the program was interrupted. If the machine is fitted with an automatic unlocking circuit and if during the power cut the door lock gets unlocked (and the door remains closed), the message **Continue / Unload** is displayed. Press the **START** button in order to continue the wash program. If the door has been opened, the wash program gets cancelled.

Version Xcontrol Plus

If a power cut occurs and the door remains closed, the message **Continue / Unload** is displayed after the power supply is restored. Press the **START** button in order to continue the wash program. If the door has been opened, the wash program gets cancelled.

How to open the door by failure

See Installation and maintenance manual.

Operation

First service at technical problem

N°	Failure message	Failure	Action	Fault occurrence
E2	No Drain	Drain failure	Full Stop + tumble	Draining sequence
E3	Tilt Fault	Out of balance	Full stop + tumble	Whole cycle
E4	Imbalance	Out of balance : Normal spin	Skip + continue	After 5 attempts to spin
E5	Tilt High Sp	Out of balance : high spin	Full stop + safety time	>500 or 750 RPM
E6	Door Coil	Door switch failure	Full stop + safety time	Whole cycle
E7	Door Switch	Door solenoid switch failure	Full stop + safety time	Whole cycle
E8	Door Start	Door lock check at start failure	Don't start	At start up
E9	Door Unload	Door lock switch closed failure	Don't start	End cycle
E11	No Fill	Fill failure	Full stop + request for Continue	While filling
E12	Overfill	Overfill failure	Full stop + tumble	While filling
E13	No Heating	Heating failure	Full stop + tumble	While heating
E14	Heat Time	Heating time failure	Full stop + request for Continue	While heating
E15	Too Hot	Too Hot	Full stop + tumble	While heating
E21	Overflow	Overflow failure	Full stop + tumble	Wash step
E24	Level Sens	Defective level sensor	Continue + Don't start	Before start up
E25	Temp Sensor	Defective temperature sensor	Continue + Don't start	Before start up
E26	Mitsub code	Undefined frequency inverter error code	Full stop + tumble	Whole cycle
E27	Comm fault	Communication fault inverter	Full stop + safety time	Whole cycle
E28	THT time / E.OL	THT Time out / E.OL	Full stop + safety time	At spin sequence
E29	OV3 time / E.OP	OV3 Time out / E.OP	Full stop + safety time	At spin sequence
E31	Load Parr	Initialization fault inverter	Don't start	At initialization
E32	Verify Parr	Verification fault inverter	Don't start	At loading parameters
E35	Wrong Softw	Wrong software version	Don't start	New software version
E37	No Drain Sp	Drain failure at the Spray Sequence	Full stop + tumble	Spray Sequence
E39	Out of Soap	The Soap Supplies are running Out of Soap	For Info only	Wash step
E41	Service Due	Service Due Warning	For Info only Open door = reset	End cycle
E42	Connection	No Network Connection	For Info only	Data Transfer Networking

Operation

E43	Voltage Par	Wrong Voltage Range Selection	Make correct selection	Configuration menu
E80	Time Out Input16	On Hold Signal Failure Soap Dispensing System	Full stop + tumble.	Whole cycle
E81	No Reheat	Heating Failure	Full stop + tumble.	Wash Step (Traceability only)
E82	No Refill	Refill failure	Full stop + request for Continue	Wash Step (Traceability only)
E83	Cycle Fail	No successful wash cycle termination	Info that the wash cycle has to be repeated.	Abnormal Cycle Termination (Traceability only)
E85	RTC Low Batt	Real Time Clock, No Battery or battery low power	For Info only.	End cycle (Traceability only)
E300-E353	MIT S ERR	Specific Mitsubishi Inverter Alarm	Full stop + safety time	Whole cycle
E500-E525	MEMORY ERR	Memory Error	Full stop + safety time	Any time
E550	TRACEYBILITY WRITE	Internal memory Error data for traceability	For Info only	Traceability function, whole cycle
E551	TRACEYBILITY FULL	Internal Traceability memory is full	For Info only	Traceability function, whole cycle
E600-E628	SOFTW ERR	Software Error	Full stop + safety time	Any time

Technical data

Technical data

		8 kg / 18 lb	11 kg / 25 lb	14 kg / 30 lb
Innerdrum volume	litres	75	105	135
	diameter	530	620	620
Drum speed wash extraction		49	49	49
	rpm	1165	1075	1075
Heating	electricity	6 / 9	6 / 9 / 12	9 / 12
	steam	1 - 8	1 - 8	1 - 8
	hot water	90	90	90
G-factor		400	400	400
Weight, net	kg	175	200	240
Sound pressure level	dB (A)	< 65	< 65	< 65

Tab.1

Connections

		8 kg / 18 lb	11 kg / 25 lb	14 kg / 30 lb
Water valves connection	BSP	DN20 3/4"	DN20 3/4"	DN20 3/4"
	kPa	100-800	100-800	100-800
Water pressure				
Rec. water pressure	kPa	300-500	300-500	300-500
Capacity	l/min	20	20	20
Drain valve	outer Ø mm	76	76	76
	Flow amount with drain valve/min	210	210	210
Steam valve connection	BSP	DN15 1/2"	DN15 1/2"	DN15 1/2"
Steam pressure	kPa	100-800	100-800	100-800

Tab.2

Technical data

Machines 8-11-14 kg / 18-25-30 lb

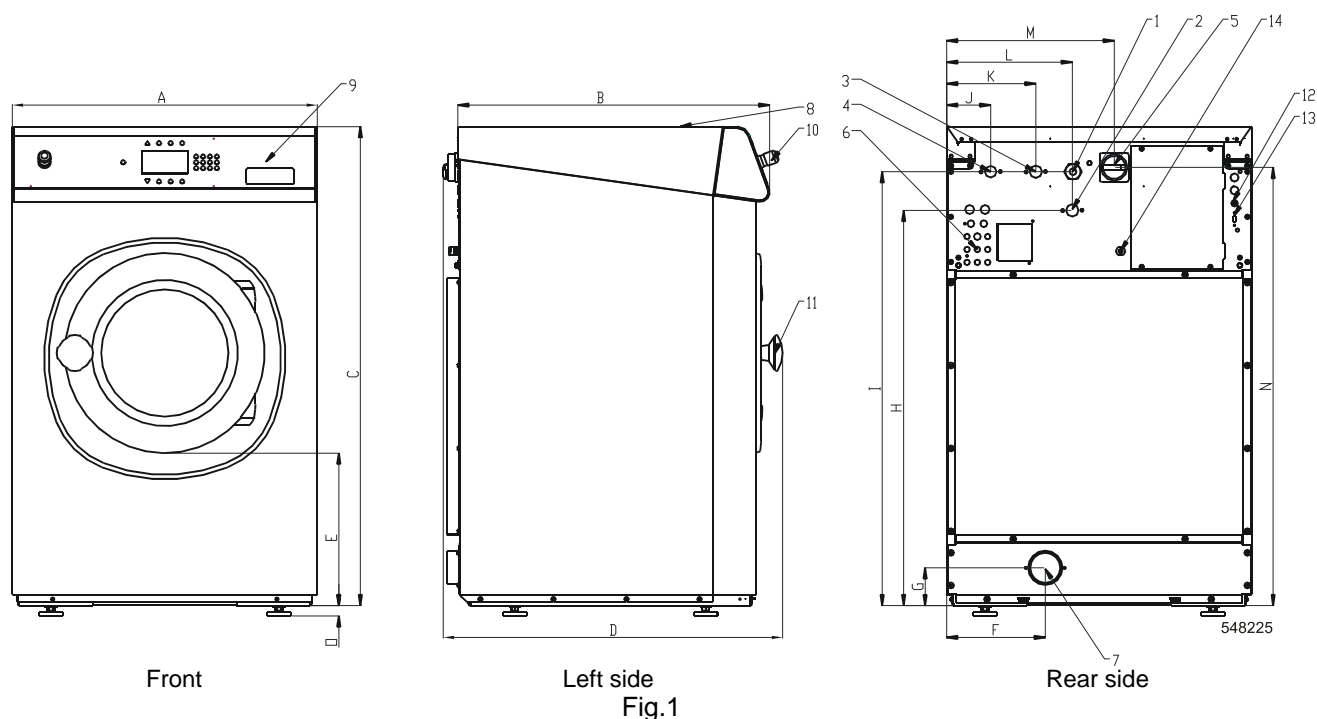

- | | |
|---------------------------|--|
| 1. Electrical connection | 8. Soap dispenser |
| 2. Hot water | 9. Control panel |
| 3. Cold water hard | 10. Button CENTRALSTOP |
| 4. Cold water soft | 11. Door opening: 8 kg / 18 lb: \varnothing 330, 11-14kg / 25-30lb : \varnothing 410 |
| 5. Main switch | 12. Fuses |
| 6. Connection liquid soap | 13. USB port |
| 7. Drain | 14. Electrical connection to liquid soap pumps |

	A	B	C	D	E	F	G	H	I	J	K	L	M	N	O
8 kg / 18 lb	710	726	1115	790	355	230	88	920	1010	103	208	293	390	1020	24
11 kg / 25 lb	795	761	1225	792	342	230	88	1030	1120	103	208	379	475	1130	24
14 kg / 30 lb	795	911	1225	942	342	230	88	1030	1120	103	208	379	475	1130	24

Tab.3

		8 kg / 18 lb	11 kg / 25 lb	14 kg / 30 lb
Frequency of the dynamic force	Hz	19,4	17,9	17,9
Floor load at max extraction	kN	1,9 \pm 0.5	2,2 \pm 0.5	2,6 \pm 0.5

Tab.4

Technical data

Machine 8 kg / 18 lb			not standard						
Phase	Voltage [V]	Frequency [Hz]	Capacity [kg]	Spin [RPM]	Total power [kW]	Fuse [A]	Motor output [kW]	Heating [kW]	Internal protection IP
1	200-240	50/60	8	1165	0,85	10	0,75	0	43
1	200-240	50/60	8	1165	5,2	32	0,75	4,6	43
3	200-240	50/60	8	1165	0,85	10	0,75	0	43
3	200-240	50/60	8	1165	6,7	25	0,75	6	43
3	200-240	50/60	8	1165	9,7	32	0,75	9	43
3	380-415 + N	50/60	8	1165	0,85	16	0,75	0	43
3	380-415 + N	50/60	8	1165	6,7	16	0,75	6	43
3	380-415 + N	50/60	8	1165	9,7	20	0,75	9	43
3	380-415	50/60	8	1165	0,85	10	0,75	0	43
3	440-480	50/60	8	1165	0,85	10	0,75	0	43
3	380-415	50/60	8	1165	6,7	16	0,75	6	43
3	440-480	50/60	8	1165	7,7	16	0,75	7	43
3	380-415	50/60	8	1165	9,7	20	0,75	9	43
3	440-480	50/60	8	1165	9,7	16	0,75	9	43

Tab.5

Machine 11 kg / 25 lb			not standard						
Phase	Voltage [V]	Frequency [Hz]	Capacity [kg]	Spin [RPM]	Total power [kW]	Fuse [A]	Motor output [kW]	Heating [kW]	Internal protection IP
1	200-240	50/60	11	1075	1,2	16	1,1	0	43
1	200-240	50/60	11	1075	5,4	32	1,1	4,6	43
3	200-240	50/60	11	1075	1,2	16	1,1	0	43
3	200-240	50/60	11	1075	6,8	25	1,1	6	43
3	200-240	50/60	11	1075	9,8	32	1,1	9	43
3	200-240	50/60	11	1075	12,8	40	1,1	12	43
3	380-415 + N	50/60	11	1075	1,2	16	1,1	0	43
3	380-415 + N	50/60	11	1075	6,8	16	1,1	6	43
3	380-415 + N	50/60	11	1075	9,8	20	1,1	9	43
3	380-415 + N	50/60	11	1075	12,8	25	1,1	12	43
3	380-415	50/60	11	1075	1,2	10	1,1	0	43
3	440-480	50/60	11	1075	1,2	10	1,1	0	43
3	380-415	50/60	11	1075	6,8	16	1,1	6	43
3	440-480	50/60	11	1075	7,8	16	1,1	7	43
3	380-415	50/60	11	1075	9,8	20	1,1	9	43
3	440-480	50/60	11	1075	9,8	16	1,1	9	43
3	380-415	50/60	11	1075	12,8	25	1,1	12	43
3	440-480	50/60	11	1075	12,8	25	1,1	12	43

Tab.6

Technical data

Machine 14 kg / 30 lb			not standard						
Phase	Voltage [V]	Frequency [Hz]	Capacity [kg]	Spin [RPM]	Total power [kW]	Fuse [A]	Motor output [kW]	Electrical heating [kW]	Internal protection IP
1	200-240	50/60	14	1075	1,6	16	1,5	0	43
1	200-240	50/60	14	1075	5,7	32	1,5	4,6	43
3	200-240	50/60	14	1075	1,6	16	1,5	0	43
3	200-240	50/60	14	1075	7,1	25	1,5	6	43
3	200-240	50/60	14	1075	10,1	32	1,5	9	43
3	200-240	50/60	14	1075	13,1	40	1,5	12	43
3	200-240	50/60	14	1075	14,9	50	1,5	13,8	43
3	380-415 + N	50/60	14	1075	1,6	16	1,5	0	43
3	380-415 + N	50/60	14	1075	7,1	16	1,5	6	43
3	380-415 + N	50/60	14	1075	10,1	20	1,5	9	43
3	380-415 + N	50/60	14	1075	13,1	25	1,5	12	43
3	380-415 + N	50/60	14	1075	14,9	32	1,5	13,8	43
3	380-415	50/60	14	1075	1,6	10	1,5	0	43
3	440-480	50/60	14	1075	1,6	10	1,5	0	43
3	380-415	50/60	14	1075	7,1	16	1,5	6	43
3	440-480	50/60	14	1075	8,1	16	1,5	7	43
3	380-415	50/60	14	1075	10,1	20	1,5	9	43
3	440-480	50/60	14	1075	10,1	16	1,5	9	43
3	380-415	50/60	14	1075	13,1	25	1,5	12	43
3	440-480	50/60	14	1075	13,1	25	1,5	12	43
3	380-415	50/60	14	1075	14,9	32	1,5	13,8	43
3	440-480	50/60	14	1075	14,9	32	1,5	13,8	43

Tab.7

Installation

Installation

Transportation and unpacking

The machine is delivered complete with feet etc. packed inside the machine in the drum.

The machine is delivered bolted onto the transport pallet and packed in a shrink-wrap foil or box.

- Remove packing from the machine.
- Remove front and rear panel. Remove the bolts between the machine and pallet.
- Mount front and rear panel.

When the machine is lifted off the pallet: Make sure that the machine does not come down on the floor with either of the rear corners first. The side panel of the machine can be damaged.

- Mount the feet.
- Place the machine on its final position.
- Level the machine with the feet of the machine.

The machine also comes with transport safety devices (four plate angles between the support and the drum).

In order to remove the safety devices:

- Remove front and rear panel, see fig.2., pos.3, 4.
- Remove both front metal transport holders, pos. 1.
- Remove both rear transport holders, pos. 2.
- The machine may not be moved with the transport holders removed. Save the transport securities for future use.

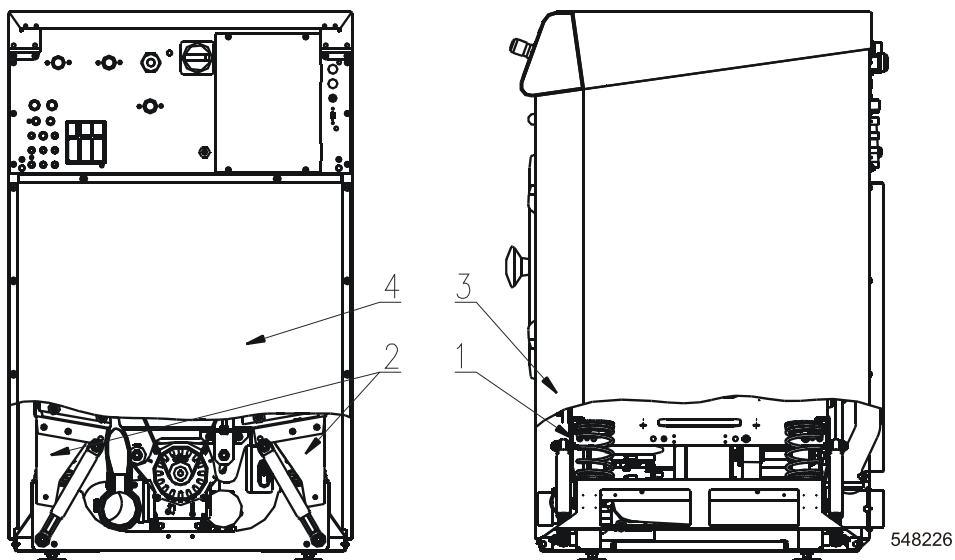

Fig.2

Installation

Siting and floor

Install the machine close to a floor drain or open drain.

In order to make installation and servicing the machine easier the following clearances are recommended:

- At least 500 mm between the machine and the wall behind
- and min. 50 mm on both sides of the machine whether installed next to the wall or other machines.

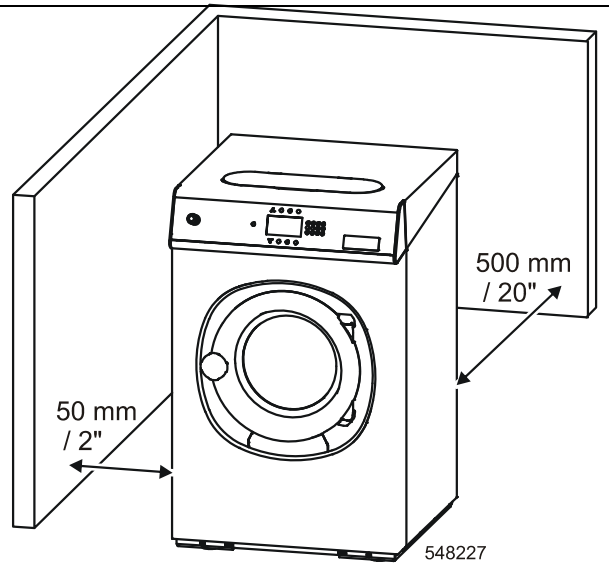

Fig.3

Installation

Mechanical installation

- Mark and drill 2 holes \varnothing 10 mm and 50 mm deep in the positions shown.

⊙ - Position of feet

○ - Drilling points for expander bolts

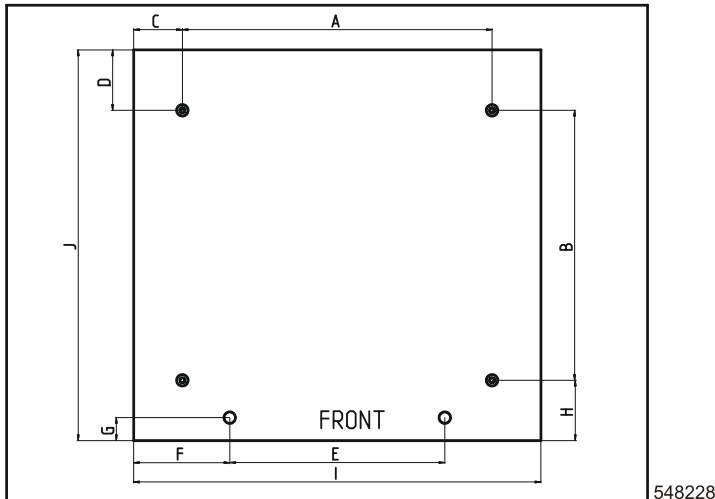

Fig.4

548228

Mechanical installation

Machine	A	B	C	D	E	F	G	H	I	J
8 kg / 18 lb	530	444	95	129,5	375	167,5	40	118	710	691,5
11 kg / 25 lb	618	444	88,5	129,5	455	170	35	118	795	691,5
14 kg / 30 lb	618	564	88,5	159,5	515	140	60	118	795	841,5

Tab.8

- The machine shall be lifted in the bottom frame.
- Place the machine over the two drilled holes.
- Check that the machine is in level.
Adjust with the feet.

⚠ WARNING!
IT IS OF UTMOST IMPORTANCE THAT THE MACHINE IS PLACED IN LEVEL, FROM SIDE TO SIDE AS WELL AS FRONT TO REAR. IF THE MACHINE IS NOT PROPERLY LEVELED, IT MAY RESULT IN OUT-OF-BALANCE WITHOUT A REAL OUT OF BALANCE IN THE DRUM.

- Mount the expander bolts in the holes drilled in the floor. Fit the washers and nuts, and tighten well.

Installation

Water connections

All intake connections to the machine are to be fitted with manual shut-off valves and filters, to facilitate installation and servicing.

Water pipes and hoses should be flushed clean before installation. After installation hoses should hang in gentle arcs.

All connectors present on the machine must be connected up. The table shows the possible connection options, which will depend on the water types to be connected to the machine. Check the machine plates too.

All water connectors must be connected up, otherwise the wash program will not function correctly.

Hoses are to be of an approved type and grade and comply with IEC 61770.

Machines shall be connected with new water hoses. Re-used water hoses must not be used.

The water pressure data: see - Technical data - Connections

<p> WARNING! IF THE WATER PRESSURE IS BELOW THE MIN. VALUE, THE WASH RESULT CAN NOT BE GUARANTEED FOR CERTAIN PROGRAM.</p>

Installation

Water type	Water connection		
	1	2	3
cold and hot	cold	-	hot
cold soft and cold hard and hot	cold soft	cold hard	hot

Tab.9

2 waters

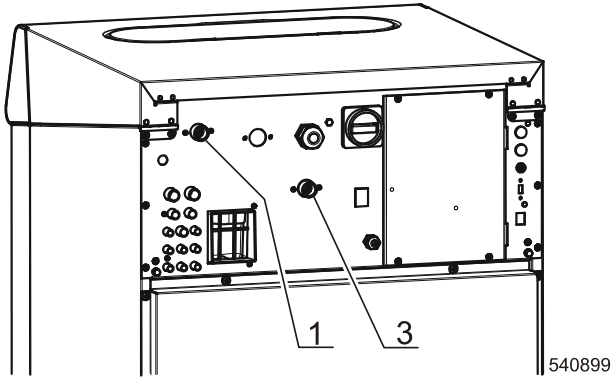

Fig.5

3 waters

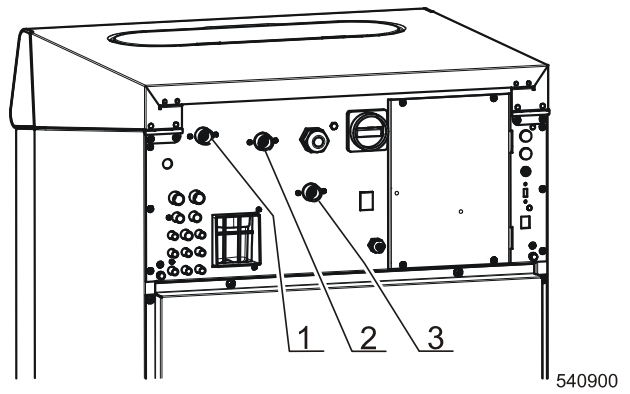

Fig.6

Installation

Drain connection

Connect a 76 mm (3") pipe or rubber hose to the machine's drain pipe, ensuring a downward flow from the machine. Avoid sharp bends which may prevent proper draining.

The drainage pipe should be located over a floor drain, drainage channel.

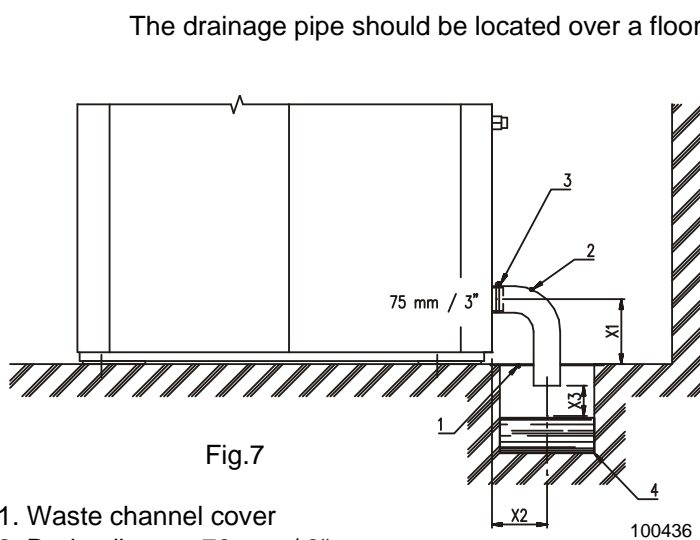

Fig.7

1. Waste channel cover
2. Drain elbow \varnothing 76 mm / 3"
3. Clamp
4. Waste channel

Recommended distances for 8-11-14 kg / 18-25-30 lb

x1 = 112 mm

x2 = >100 mm

x3 = >20 mm

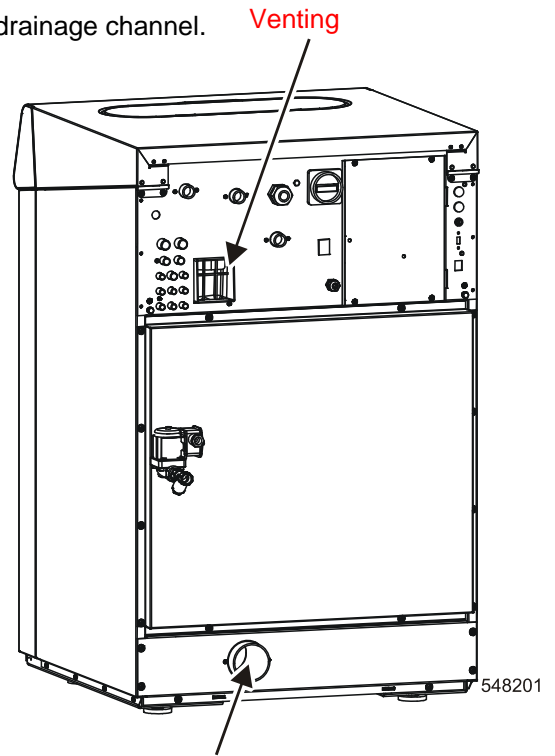

Fig.8 Drain connection

The main drain channel-pipe must have the capacity to be able to handle the total output of all connected machines. In a drainpipe, a deodorizer must be provided every twenty meter, fig.9., pos.1 to assure the good working of the drain pipe. If the main drain pipe cannot be sufficiently deodorized, install a deodorizer per machine. Every time a machine is coupled on the drainpipe, the diameter of the tube or the width of the waste channel must be more. See, fig.9., D1, D2, D3.

The recommended drain pipes diameter are:

D1 = 75 mm / 3" for one machine

D2 = 100 mm / 4" for two machines

D3 = 125 mm / 5" for three machines

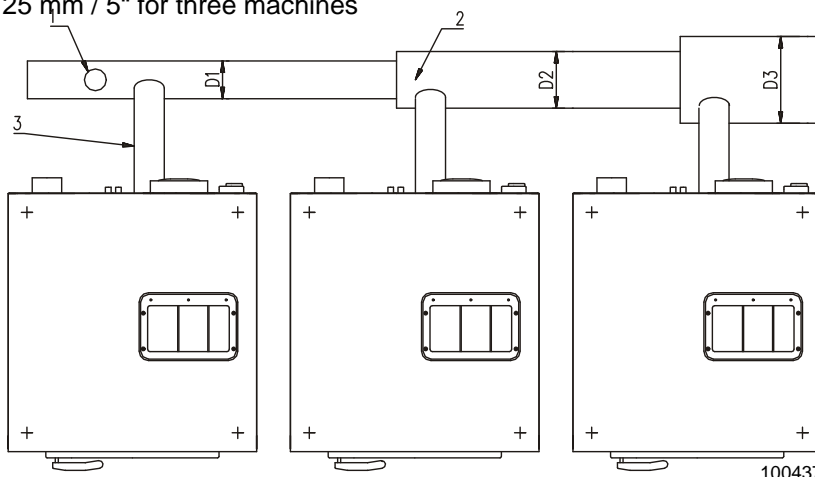

Fig.9 Recommended drain pipe diameters

Installation

Venting

<p>⚠ WARNING VAPOURS ESCAPE FROM THE MACHINE THROUGH THE AIR VENT OPENING! SEE (FIG.8). DO NOT COVER!</p>
--

Liquid soap connection

General : Always use liquid soap pumps with a flow rate that can bring the requested quantity in less than 30sec.

Important : Start pumping immediately after the water valves are open. The incoming water dilutes the liquid soap and brings it into the tub assembly.

Caution: The machines are produced in two versions:
Without liquid soap (standard version)
With liquid soap (according to the request)

Secure the location of the wiring and hoses in such a way that they can not be pinched, damaged or rubbed. Before you start to use liquid soap, check with your liquid soap supplier whether the liquid soap is harmless and inert to PP and PVC material in order to avoid a problem that manufacturer is not responsible for.

The washer has provisions for connecting external dosing of liquid soaps. On the back side, a plastic hose connection part is present, fig.10., pos.1. to connect the liquid soap hoses. Depending of the number of liquid soap pumps that will be used, drill holes (max. 8) of \varnothing 8 mm / 0.315" in the plastic hose connection part for each pump.

On the plastic hose connection part is also a 3 nipples of \varnothing 12 mm / 1/2". Use this nipple ONLY for entering diluted soap. Drill with \varnothing 11.5 mm / 0.45". By default, these nipples are closed. Drill only the ones that will be used.

Take care that the drill particles are carefully removed so that they can not clog up the hoses and openings.

check that the hose connections are tight (check the clamps)! any leakage of chemicals may cause serious body injuries as well as serious damage to the washer. if one of the nipples are open, close and secure the opening with an appropriate cover.

Installation

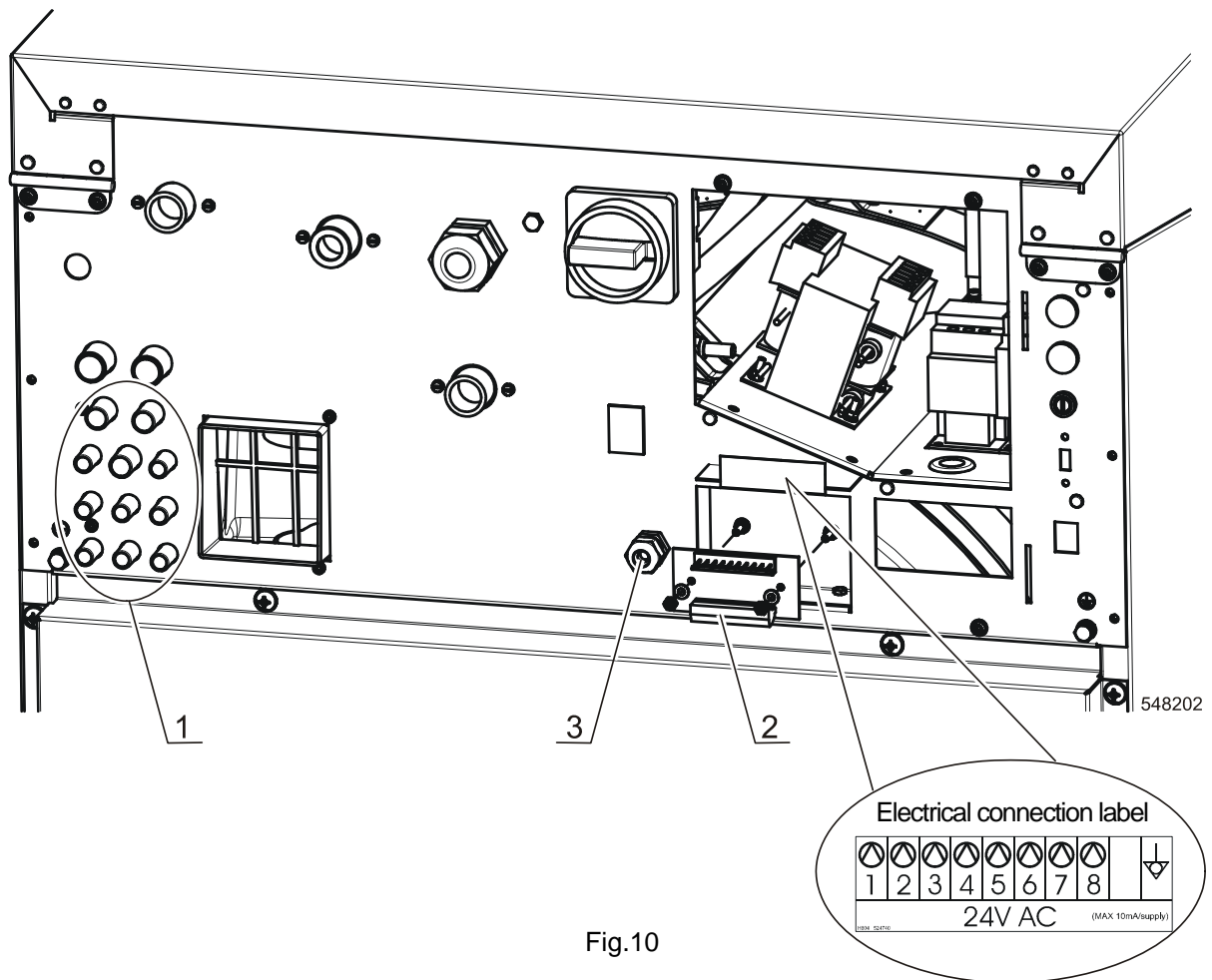

Fig.10

Electrical connection

The power supply of the liquid soap supply system has to be connected to an external electrical source. Only authorized workers with a valid qualification must execute the electrical connection on the machine according to the valid local standards. The correct connection way can be found on the wiring diagram that is located inside the cabinet in a plastic bag. Do not connect the liquid soap pump system in the washer.

Electronic controller with blue pcb and graphical display

For electric connection of supply control signals is available on the back side of the machine the terminal box with LED signalization of activation of the respective pump, (see fig.10., pos.2). Above the terminal box there is a label for electric connection, fig.10. Detail connection of signals could be also found on the electric scheme of the machine. Signals for supply pumps control are 24V AC. Maximum current for control circuits of pumps must be limited to 10mA. Lead the cable for connection of pumps control signals through the plastic cable bushing, pos.3. After connection of conductors to the respective positions of the connector "P" (screw clamps), fix up the cable by tightening the cable bushing) against disconnection and close the box with the cover. For details about liquid soap supply system programming, see Programming manual.

Installation

Electrical installation

General

The machine has been designed for connecting to the electrical network according the specification of your order. Before connection check the electrical data stated on the data plate, if they correspond to your electrical network. An individual branch circuit needs to be used for each machine. The way of the connection is described in fig.11. For electrical protection, there must be installed a residual current device (RCD) and a circuit breaker in the electrical installation of the building (laundry switchboard). For correct selection see below.

IMPORTANT:

- If the machine is not equipped with a main switch then supply disconnecting devices need to be provided in the installation for all electrical supplies connected to the machine, in accordance with EN 60204-1 standard, point 5.3.
- Make sure the supply voltage is always within the limits specified in the chapter “TECHNICAL DATA” in all circumstances. When you have long distances in the electrical installation, it may be necessary to use bigger cables to reduce the voltage drop.
- When the machine is connected near a large capacity power supply transformer (500kVA or more, wiring length shorter than 10 m) or there is a power capacitor switch-over, a power supply improving reactor must be installed. If you do not install this, the inverter may get damaged. Contact your sales office for more info.

⚠ WARNING!
GROUNDING: IN EVENT OF MALFUNCTION OR BREAKDOWN OR LEAKAGE CURRENT, THE GROUNDING WILL REDUCE THE RISK OF ELECTRICAL SHOCK AND SERVE AS A PROTECTING DEVICE, BY PROVIDING A PATH OF LEAST RESISTANCE OF ELECTRICAL CURRENT. THEREFORE IT IS VERY IMPORTANT AND THE RESPONSIBILITY OF THE INSTALLER TO ASSURE THE WASHER IS ADEQUATELY GROUNDED AT THE POINT OF INSTALLATION TAKING INTO CONSIDERATIONS THE NATIONAL AND LOCAL CONDITIONS AND REQUIREMENTS.

1. Residual current device (RCD)
2. Laundry electrical switchboard
3. Supply protection device
4. Washing machine
5. Phase conductors
6. Protective conductor
7. Main switch inlet terminal switchboard
8. Neutral conductor

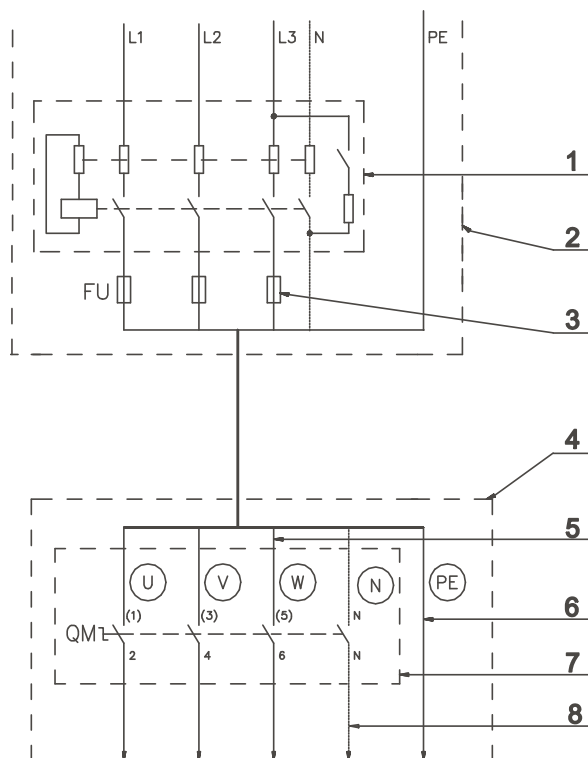

505529

Fig.11 Machine connection to electrical network (with a residual current device)

Installation

Residual current device (RCD)

In some countries an RCD is known as an “earth leakage trip” or “Ground Fault Circuit Interrupter” (GFCI) or an “Appliance Leakage Current Interrupter” (ALCI) or “earth (ground) leakage current breaker”.

Specifications:

- Tripping current: 100mA (if locally not available/allowed use a 30mA trip current, preferably selective type with small time delay set)
- Install max. 2 machines on each RCD (for 30mA, only 1 machine)
- Type B. There are components inside the machine which make use of DC voltages and therefore a “type B” RCD is necessary. For information only: Type B is better performance than type A, and type A is better than type AC.

When locally allowed, there must always be installed an RCD. In some power network earthing systems (IT, TN-C,...), an RCD might not be allowed (see also IEC 60364).

Some washer control circuits are supplied with a separating transformer. Therefore the RCD may not detect faults in the control circuits (but the fuse(s) of the separating transformer will).

Supply protection device

A supply protection device basically protects the machine and wiring against overloads and short circuits. As supply protection device, you can use either (glow-wire) fuses or (automatic) circuit breakers.

See “Technical data” for the rating of the nominal current and other specifications of the supply protection device. In this table there is specified that the protection must be the “slow” type, for circuit breakers this means curve D. Although not recommended, if for some reason you can not use a slow type, select the protection device with 1 step higher nominal current rating to avoid disconnecting during start-up.

Supply cable

The supply cable is not delivered with the machine.

Specifications:

- conductors with copper cores
- stranded conductors are strongly recommended (flexible wiring) to avoid conductor breaking because of vibration
- **THE CROSS SECTION DEPENDS ON THE USED SUPPLY PROTECTION DEVICE. SEE TABLE 10., FOR THE MINIMAL CROSS SECTION**
- As short as possible, directly from the supply protection device to the washer without branching off.
- No plug or extension cords: The machine is intended to be permanently connected to the electrical network

Connection:

- Insert the cable through the hole in the on the rear panel, insure a strain relief (turnbuckle) is used so that the supply cable can not move.
- Strip the conductor ends according fig.12.
- The protective conductor must be longer so that when the cable is pulled out accidentally, this conductor is disconnected the last one!
- With stranded conductors, use “wire end tubes” with an insulated sleeve (6) for L1/U, (L2/V), (L3/W), (N) conductors. Make sure there can not be make accidental contact, since the supply cable stays under voltage even when the main switch is off.
- Crimp a ring terminal (eyelet) to the protection conductor for good fixation to the PE terminal.
- Connect the supply cable conductors to the incoming terminals (main switch (1)) marked with L1/U, (L2/V), (L3/W), (N), and the terminal (copper screw) marked with PE, see fig.13.
- Provide a sag in the cable, in front of the cable strain relief. This will avoid ingress of condensed water into the machine, see fig.13.

Installation

Power supply protection device nominal current (US)		Min. phase conductor section in mm ² (AWG)	Min. Protection conductor section in mm ² (AWG)
Automatic circuit breakers	Fuses		
16A (15A)	10A (10A)	1,5 mm ² (AWG 15)	1,5 mm ² (AWG 15)
20A (20A)	16A (15A)	2,5 mm ² (AWG 13)	2,5 mm ² (AWG 13)
25A (-)	20A (20A)	4 mm ² (AWG 11)	4 mm ² (AWG 11)
40A (40A)	32A (30A)	6 mm ² (AWG 9)	6 mm ² (AWG 9)
63A(-)	50A (50A)	10 mm ² (AWG 7)	10 mm ² (AWG 7)
80A	63A	16 mm ²	16 mm ²
100A	80A	25 mm ²	16 mm ²
125A	100A	35 mm ²	25 mm ²

Tab.10 Manufacturer's recommended minimal conductor section

1. Protection conductor
2. Phase conductor
3. Phase conductor
4. Phase conductor
5. Neutral conductor
6. Molded tube
7. The stripped length of conductors

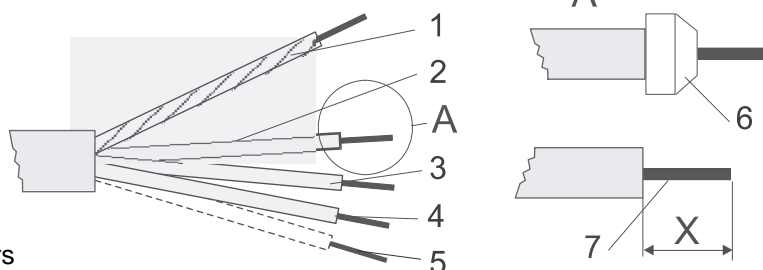

Fig.12 Adaptation of conductor ends of supply cable

505 530

1. Main switch
2. Turnbuckle
3. -
4. Sag of inlet cable

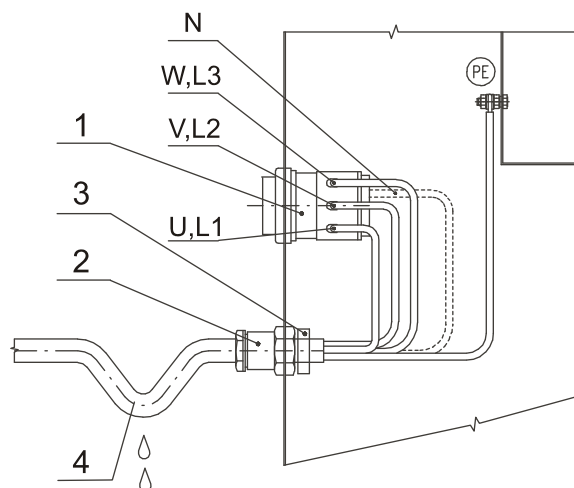

Fig.13 Connection of main power inlet

505 531

Machine protective earth connection and equipotential bonding

Independent of the supply cable, the washer must be connected to the laundry protective earth system with a separate conductor. The protection conductor, enabling this connection, is not included with the washer. If there are other washers/appliances with exposed conductive parts, which can be touched simultaneously, make sure to make equipotential bonding between all these appliances. The external protective terminal for this purpose is located on the rear panel of the machine frame, (fig.14., pos.3). The minimum protection conductor's cross section depends on the supply cable cross section and can be found in table 10. However, for the protection purposes with the supply cable section of min. 4 mm² we recommend to select a larger conductor section, i.e. 6 mm².

Installation

1. Washing machine (rear view)
2. Laundry protective earth connection
3. Washing machine external protective terminal
4. Protective conductor - washing machine connection
5. Earth mark

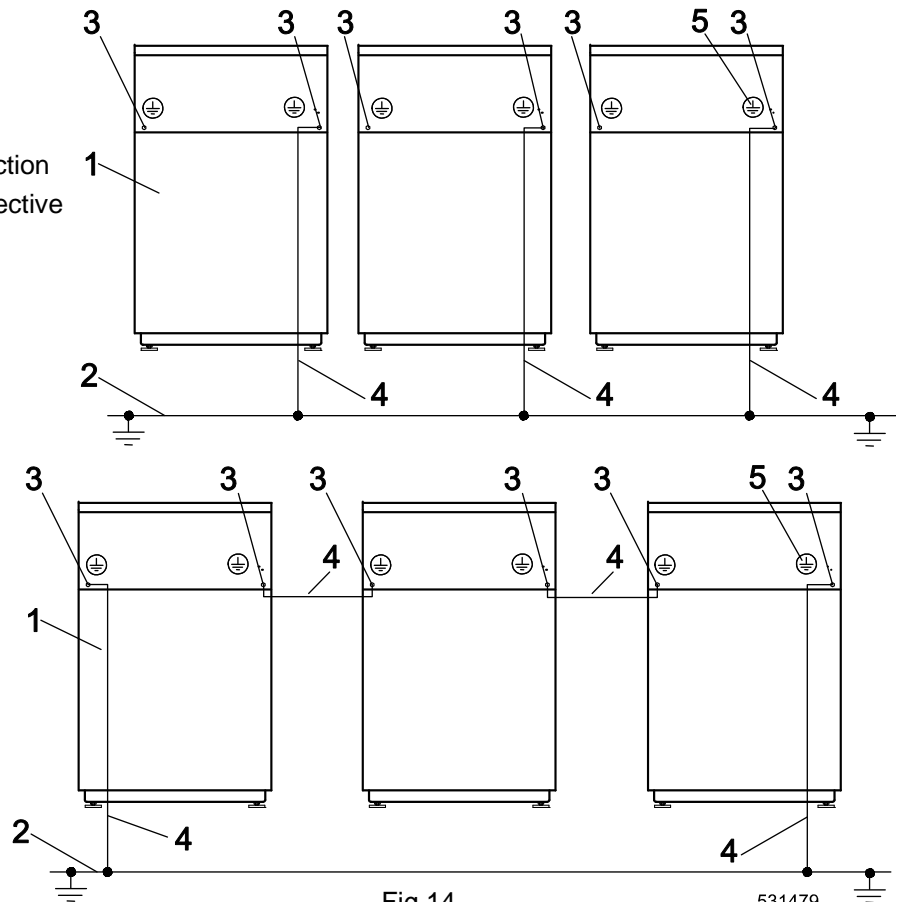

Fig.14

531479

Multiple machines in line single phase

When multiple single phase machines are connected to the same electrical network, it is necessary to connect the machines according to fig.15. The phase of the frequency control and motor which is connected to the terminal inside the machine, has to be connected alternatively for the first machine with the first phase L1 of the network, the second machine with the second phase L2, ... The fourth machine must again be connected to the first phase L1. This assures a better load of the electrical network.

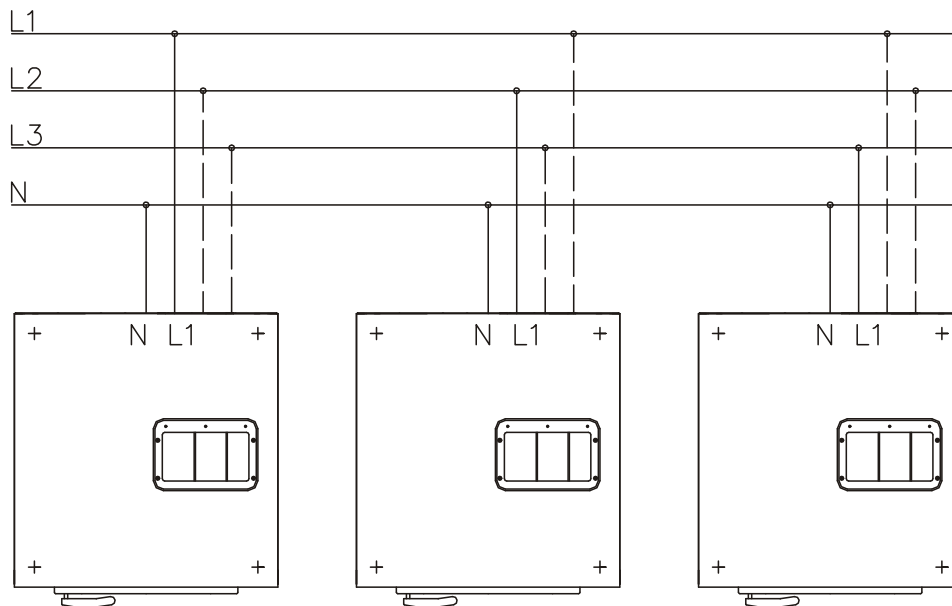

Fig.15 Multiple machines in line

100 677

Maintenance and adjustments

Maintenance and adjustments

WARNING!

ALWAYS FOLLOW SAFETY INSTRUCTIONS! DO NOT BYPASS ANY SAFETY DEVICES OR THEIR PARTS. ANY INTERFERENCE TO THE MACHINE FUNCTIONS AND CONSTRUCTION ARE PROHIBITED!

USE THE PROPER CHEMICAL AGENTS WHICH AVOID CALCIUM SEDIMENTS ON HEATING ELEMENTS AND OTHER MACHINE PARTS. DISCUSS THIS ISSUE WITH YOUR SUPPLIER OF WASHING PRODUCTS.

THE MANUFACTURER OF THE MACHINE IS NOT RESPONSIBLE FOR THE DAMAGE OF HEATING ELEMENTS AND OTHER MACHINE PARTS DUE TO CALCIUM SEDIMENTS.

DO NOT OPERATE THE MACHINE WITH BROKEN / MISSING PARTS OR OPENED COVERS! BEFORE MAINTENANCE WORK DISCONNECT THE MACHINE POWER SUPPLY!

WHEN THE MAIN SWITCH IS TURNED OFF THE INLET TERMINALS OF THE MACHINE MAIN SWITCH ARE STILL UNDER CURRENT! THAT IS THE WAY TO AVOID INJURIES.

When replacing any parts of the machine, exchange them with original parts obtained from your dealer or ordered through the spare parts manual.

Checking and maintenance daily

1. Remove the linen or other parts (paperclips, needles, ...) that are left lying in the drum to avoid injuries and damage to the rubber door seal, seals, glass etc.
2. Clean the door seal from any remaining detergent and other foreign matter.
Do not use solvents, acids or grease to clean the rubber door gasket!
3. Clean the top and body when water or detergent traces are on the machine. Use a dampened cloth, do not use abrasive cleaners. Dry with a soft cloth.
4. Hoppers must be cleaned at the end of each working day. Remove sediments inside the reservoir by means of a plastic spatula and splash by water.
5. Check water and possible steam inlets for leakage.
6. At the end of the working day, open the machine door to allow airing out the machine and to prolong the door gasket life service. We recommend to shut off all electrical power inlets and main water inlets.

Checking and maintenance every three months

1. Check if the drain valve is not leaking during the wash process. It is also important that the valve opens properly afterwards (drain valve opens when electrical power falls out). Wash out the drain if the water doesn't drain fluent.
2. Check for the belt tightness or possible damage; therefore remove the machine rear cover.
3. Check the tightness of the bolts according to chapter "Tightening moments".
4. Check visually all hoses and connection inside the machine for leaking.
5. Make sure that the control components are protected against moisture and dust during the clean up. Wipe and clean up the machine inside.
6. On machines with electric heating check the tightening of the contacts of heating elements terminals and other power terminals (main switch, fuse disconnectors, contactors).
7. Tighten the contacts of heating elements terminals on machines with electrical heating.

Maintenance and adjustments

Checking and maintenance every six months

1. The filters in the water connection at the valves need to be cleaned. Turn off the tap. Unscrew the hoses at the back of the appliance. Take out the filter at the center with pointed pliers, clean and re-insert. When re-attaching the hoses, make sure that the seals are seated correctly. Check water inlets for leaks. Tighten the connections or replace the seals of the inlet hose if necessary.



WARNING!

BEFORE REMOVING TOP OR BACK PANEL OF THE MACHINE, SWITCH POWER OFF AND WAIT FOR AT LEAST 10 MINUTES. BEFORE STARTING INSPECTION OF FREQUENCY INVERTER, CHECK FOR RESIDUAL VOLTAGE ACROSS MAIN CIRCUIT TERMINALS + AND -. THIS VOLTAGE MUST BE BELOW 30VDC BEFORE YOU CAN ACCESS THE INVERTER FOR INSPECTION.

2. Remove dirt and dust, clean, and verify functionality from:

- the cooling fin of the inverter
- the motor cooling fins
- the internal ventilator of the inverter (if present)
- the external ventilator (if present)
- the external air relieves of the machine

Maintenance and adjustments

Replacement of door rubber

1. Open the door. Remove the door glass with rubber from the door frame by pushing it towards the drum. Do it carefully, do not damage the glass.
2. Remove the gasket from the glass.
3. Place a new rubber gasket with wider groove on the glass with the edge up.
4. Moisten the seal groove for door with soap water. Place a smooth cord in the groove all around. Tighten up the margin by cord and fit the unit to the door opening. Hold one end of the cord firmly on the door. Pull the other cord end towards the center of the glass for the rubber edge properly fit in.

Important note: After the door seal replacement it can happen that the door seal pressure is too high on the door lock side as well as on the hinge side. If this happens, follow the service instructions mentioned above.

Adjusting of out of balance switch

The out of balance switch is an important component which must - if correctly adjusted - stop the machine when excessive movement and shaking occur due to an unbalance caused by improper distribution of linen in the washing drum. The adjustment of the vibration switch has ALWAYS to be executed at the installation of the washer. It is recommended that once a year a qualified worker verifies the vibration switch setting.

⚠ ATTENTION!
DO NOT USE THE MACHINE IF THIS FUNCTION DOESN'T WORK PROPERLY!
THIS FUNCTIONAL TEST CAN ONLY BE EXECUTED BY A QUALIFIED TECHNICIAN WITH PROPER AUTHORIZATION.

Belt replacement and adjusting tension

⚠ WARNING!
MAKE SURE THE MACHINE IS DISCONNECTED FROM POWER SUPPLY BY USE AND SECURE THE DISCONNECTING DEVICE.

On a new machine and after a belt replacement, make an inspection of the belt tightness:

1. After first 24 hrs of operation
2. After first 80 hrs of operation
3. Every 6 months or every 1000 operation hours - which ever comes first.

The belts are accessible from the rear of the machine. If the belts are too tight or too loose, the durability will be shortened. If too loose they can be slipping on the pulley and can cause a noisy operation and generate excessive wear with fast breaking as consequence. In such cases correcting the belts tension is necessary. The belt tension can be verified with an approximate method.

⚠ ATTENTION!
TO CHANGE THE BELTS: NEVER USE A CROWBAR, SCREW DRIVER OR ALIKE TO TAKE OFF THE BELTS OVER THE PULLEY!

Water filters

Machines are equipped with filters on water inlets. It is necessary to clean up the filters occasionally to avoid a prolongation of filling the machine with water. Intervals of cleaning depend on the quality of the water, for example foreign particles in the water line.

⚠ WARNING!
BEFORE YOU START CLEANING THE WATER FILTERS, CHECK IF ALL WATER INLET TO THE MACHINE IS CLOSED.

Maintenance and adjustments

Tightening moments

The recommended torque values for standardized steel bolts:

M6 8.8: C = 10 Nm

M8 8.8: C = 25 Nm

M10 8.8: C = 45 Nm

M12 8.8: C = 80 Nm

M16 8.8: C = 200 Nm

Replacement washer fuses

Fuse values

The correct values of fuses can be found in the vicinity of the fuse holders and on the electrical scheme and delivered with the machine. When a fuse is blown, you can replace it with the same value but in **NO** case a higher value. If the fuse blows again, do not change it, but find the cause of the failure.

Contact your commercial distributor for help if necessary.

Trouble shooting aids

Trouble shooting aids

Unblocking of the door lock in case of emergency

If the power blackout takes too long, you can make an emergency unblocking of the door lock. The emergency door opening has been described as follows:

⚠ WARNING!

BEFORE THE EMERGENCY DOOR OPENING TURN OFF THE MACHINE MAIN SWITCH!
NEVER OPEN THE DOOR WHILE DRUM IS STILL RUNNING!
NEVER OPEN THE DOOR IF “TOO HOT” IS INDICATED! RISK OF BURN OR SCALD INJURIES!
NEVER OPEN THE DOOR IF THE MACHINE PARTS FEELS TOO WARM!
NEVER OPEN THE DOOR, UNTIL THERE IS NO WATER IN THE DRUM! IN THE OPPOSITE CASE, IT WILL FLOW OUT AFTER OPENING THE DOOR.

1. Verify if all condition are present to safely open the door.
2. Softly push the washing unit to back.
3. Put your fingers over the edge of the front panel at the door lock side.
4. Push the emergency door opening button.
5. Open the door if all safety conditions are fulfilled.

Error indication shown on display

See User's manual, chapter 5.

See Programming manual, chapter “Troubleshooting”.

Trouble shooting aids

List of recommended spare parts

- drain valve
- 2-way inlet valve
- 3-way inlet valve
- 4-way inlet valve
- steam valve
- door lock
- fuses
- thermostat sensor
- motor contactor
- heating contactor
- heating element
- V-belts
- door seal

Find more detailed information and order codes in the spare parts catalogue for individual machines at your dealer.

IMPORTANT !

MACHINE TYPE:

PROGRAMMER:

Electronic timer

INSTALLATION DATE:

**INSTALLATION
CARRIED OUT BY:**

SERIAL NUMBER:

ELECTRICAL DETAILS:

.....**VOLT**.....**PHASE**.....**HZ**

NOTE:

ANY CONTACTS WITH YOUR DEALER REGARDING MACHINE SAFETY, OR SPARE PARTS, MUST INCLUDE THE ABOVE IDENTIFICATION.

MAKE CERTAIN TO KEEP THIS MANUAL IN A SECURE PLACE FOR FUTURE REFERENCE.

DEALER:

